



Service Manual

Models: GWH07AFA-K3NNA1A
GWH09AFA-K3NNA1A
GWH09AFB-K3NNA1A
GWH12AFB-K3NNA1A
GWH12AFC-K3NNA1A
GWH18AFC-K3NNA1A
GWH24AFD-K3NNA1A
(Refrigerant R410A)

GREE ELECTRIC APPLIANCES, INC. OF ZHUHAI



Table of Contents

Part I : Technical Information	1
1. Summary	1
2. Specifications	3
2.1 Specification Sheet.....	3
2.2 Capacity Curve in Different Outdoor Temperature	11
2.3 Cooling and Heating Data Sheet in Rated Frequency	11
3. Outline Dimension Diagram	12
3.1 Indoor Unit.....	12
3.2 Outdoor Unit	13
4. Refrigerant System Diagram	17
5. Electrical Part	18
5.1 Wiring Diagram.....	18
5.2 PCB Printed Diagram	23
6. Function and Control	25
6.1 Remote Controller Introduction	25
6.2 Brief Description of Modes and Functions.....	28
Part II : Installation and Maintenance	33
7. Notes for Installation and Maintenance	33
8. Installation	36
8.1 Installation Dimension Diagram.....	36
8.2 Installation Parts-Checking	38
8.3 Selection of Installation Location.....	38
8.4 Requirements for electric connection	38
8.5 Installation of Indoor Unit.....	38
8.6 Installation of Outdoor unit	41
8.7 Vacuum Pumping and Leak Detection	42
8.8 Check after Installation and Test operation	42
9. Maintenance	43
9.1 Error code.....	43
9.2 Procedure of Troubleshooting	45
9.3 Maintenance method for normal malfunction	54

10. Exploded View and Parts List56

 10.1 Indoor Unit.....56

 10.2 Outdoor Unit.....62

11. Removal Procedure76

 11.1 Removal Procedure of Indoor Unit76

 11.2 Removal Procedure of Outdoor Unit81

Appendix:105

 Appendix 1: Reference Sheet of Celsius and Fahrenheit105

 Appendix 2: Configuration of Connection Pipe.....105

 Appendix 2: Pipe Expanding Method106

 Appendix 4: List of Resistance for Temperature Sensor107

Part I : Technical Information

1. Summary

Indoor Unit:

GWH07AFA-K3NNA1A/I
GWH09AFA-K3NNA1A/I
GWH09AFB-K3NNA1A/I
GWH12AFB-K3NNA1A/I
GWH12AFC-K3NNA1A/I
GWH18AFC-K3NNA1A/I
GWH24AFD-K3NNA1A/I

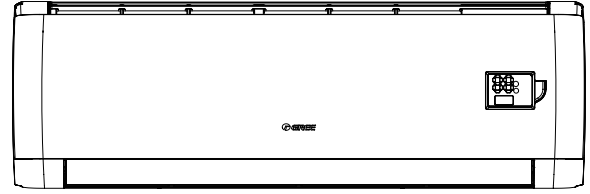

Outdoor Unit:

GWH07ACA-K3NNA5A/O
GWH09ACB-K3NNA5A/O

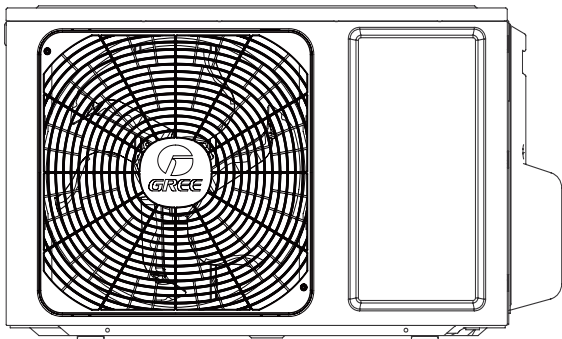

GWH12QC-K3NNA1A/O

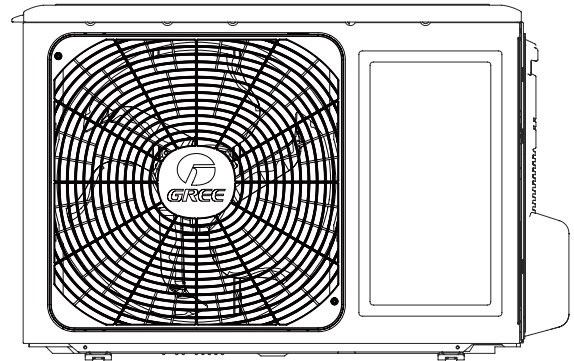

GWH12AAB-K3NNA2A/O

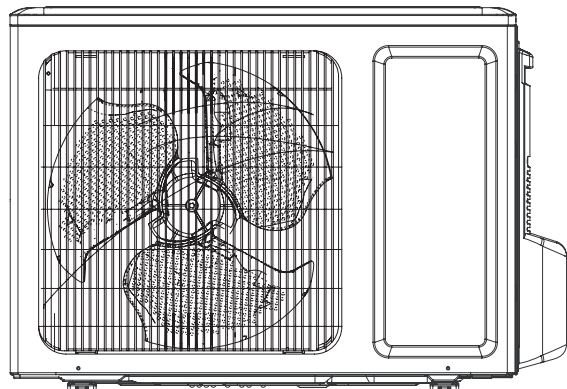

GWH18AAC-K3NNA1A/O

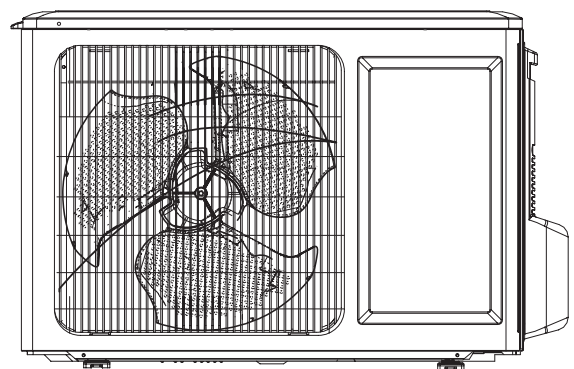

GWH09AAA-K3NNA1A/O

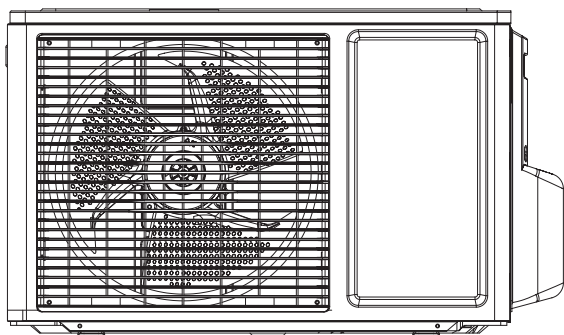

GWH24AAD-K3NNA1A/O(CA115W14300)

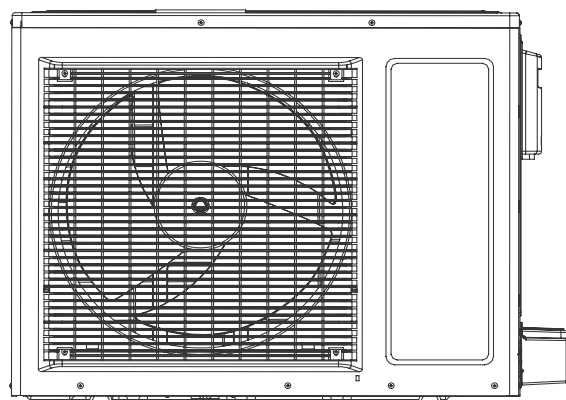

GWH24AAD-K3NNA1A/O(CA115W14301)

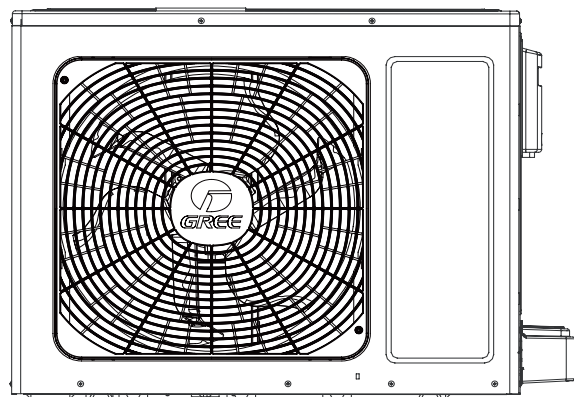

Remote Controller:

YAW1F



Models List:

No.	Model	Product Code	Model	Product Code	Model	Product Code	Remote Controller
1	GWH07AFA-K3NNA1A	CA348000400	GWH07AFA-K3NNA1A/I	CA348N00400	GWH07ACA-K3NNA5A/O	CA341W00100	YAW1F
2		CA348000401		CA348N00401			
3	GWH09AFB-K3NNA1A	CA348000300	GWH09AFB-K3NNA1A/I	CA348N00300	GWH09ACB-K3NNA5A/O	CA341W00200	
4	GWH09AFA-K3NNA1A	CA348000800	GWH09AFA-K3NNA1A/I	CA348N00800	GWH09AAA-K3NNA1A/O	CA115W14400	
5	GWH12AFB-K3NNA1A	CA348000600	GWH12AFB-K3NNA1A/I	CA348N00600	GWH12AAB-K3NNA2A/O	CA115W14100	
6	GWH12AFC-K3NNA1A	CA348000101	GWH12AFC-K3NNA1A/I	CA348N00100	GWH12QC-K3NNA1A/O	CA419W00101	
7	GWH18AFC-K3NNA1A	CA348000700	GWH18AFC-K3NNA1A/I	CA348N00700	GWH18AAC-K3NNA1A/O	CA115W14200	
8	GWH24AFD-K3NNA1A	CA348000502	GWH24AFD-K3NNA1A/I	CA348N00502	GWH24AAD-K3NNA1A/O	CA115W14300	
9		CA348000501		CA348N00500		CA115W14301	

2. Specifications

2.1 Specification Sheet

Model			GWH07AFA-K3NNA1A	GWH09AFB-K3NNA1A
Product Code			CA348000400/CA348000401	CA348000300
Power Supply	Rated Voltage	V~	220-240	220-240
	Rated Frequency	Hz	50	50
	Phases		1	1
Power Supply Mode			Indoor	Indoor
Cooling Capacity		W	2250	2638
Heating Capacity		W	2350	2755
Cooling Power Input		W	700	821
Heating Power Input		W	651	763
Cooling Power Current		A	3.5	4.0
Heating Power Current		A	3.2	3.5
Rated Input		W	1050	1150
Rated Current		A	5.5	5.6
Air Flow Volume(SH/H/M/L/SL)		m ³ /h	470/420/370/250/-	570/500/430/300/-
Dehumidifying Volume		L/h	0.6	0.8
EER		W/W	3.21	3.21
COP		W/W	3.61	3.61
SEER		W/W	/	/
HSPF		W/W	/	/
Application Area		m ²	10-16	12-18
Indoor Unit	Model of Indoor Unit		GWH07AFA-K3NNA1A/I	GWH09AFB-K3NNA1A/I
	Product Code of Indoor Unit		CA348N00400/CA348N00401	CA348N00300
	Fan Type		Cross-flow	Cross-flow
	Diameter Length(DXL)		mm	Φ93X505
	Fan Motor Cooling Speed(SH/H/M/L/SL)		r/min	1300/1200/1100/850/-
	Fan Motor Heating Speed(SH/H/M/L/SL)		r/min	1200/1100/1000/900/-
	Output of Fan Motor		W	10
	Fan Motor RLA		A	0.15
	Fan Motor Capacitor		μF	1
	Input of Heater		W	/
	Evaporator Form			Aluminum Fin-copper Tube
	Pipe Diameter		mm	Φ7.94
	Row-fin Gap		mm	1-1.2
	Coil Length (LXDXW)		mm	508X19.05X254
	Swing Motor Model			MP24AN
	Output of Swing Motor		W	1.5
	Fuse		A	3.15
	Sound Pressure Level (SH/H/M/L/SL)		dB (A)	40/38/35/26/-
	Sound Power Level (SH/H/M/L/SL)		dB (A)	50/48/45/36/-
	Dimension (WXHXD)		mm	744X256X185
	Dimension of Carton Box (LXWXH)		mm	788X314X249
Dimension of Package (LXWXH)		mm	793X330X260	
Net Weight		kg	8	
Gross Weight		kg	9.5	

Outdoor Unit	Model of Outdoor Unit		GWH07ACA-K3NNA5A/O	GWH09ACB-K3NNA5A/O
	Product Code of Outdoor Unit		CA341W00100	CA341W00200
	Compressor Manufacturer/Trademark		ZHUHAI LANDA COMPRESSOR CO.,LTD	ZHUHAI LANDA COMPRESSOR CO.,LTD
	Compressor Model		QXA-A081A130A	QXA-B102C130
	Compressor Oil		RB68EP/FVC68D/FV50S	RB68EP/FV50S
	Compressor Type		Rotary	Rotary
	L.R.A.	A	15	17
	Compressor RLA	A	3.25	4
	Compressor Power Input	W	680	865
	Overload Protector		UP3-MC0 (L)	UP3-00
	Throttling Method		Capillary	Capillary
	Operation Temp	°C	16~30	16~30
	Ambient Temp (Cooling)	°C	18~43	18~43
	Ambient Temp (Heating)	°C	-7~24	-7~24
	Condenser Form		Aluminum Fin-copper Tube	Aluminum Fin-copper Tube
	Pipe Diameter	mm	Φ7.94	Φ7.94
	Rows-fin Gap	mm	1-1.4	1-1.4
	Coil Length (LXDXW)	mm	658.3X19.05X396	655X19.05X396
	Fan Motor Speed	rpm	320	320
	Output of Fan Motor	W	20	20
	Fan Motor RLA	A	0.25	0.25
	Fan Motor Capacitor	μF	1.5	1.5
	Air Flow Volume of Outdoor Unit	m ³ /h	1200	1200
	Fan Type		Axial-flow	Axial-flow
	Fan Diameter	mm	Φ320	Φ320
	Defrosting Method		Automatic Defrosting	Automatic Defrosting
	Climate Type		T1	T1
	Isolation		I	I
	Moisture Protection		IPX4	IPX4
	Permissible Excessive Operating Pressure for the Discharge Side	MPa	4.3	4.3
	Permissible Excessive Operating Pressure for the Suction Side	MPa	2.5	2.5
	Sound Pressure Level (H/M/L)	dB (A)	49/-/-	48/-/-
Sound Power Level (H/M/L)	dB (A)	59/-/-	58/-/-	
Dimension (WXHXD)	mm	720X428X310	720X428X310	
Dimension of Carton Box (LXWXH)	mm	765X350X475	765X350X475	
Dimension of Package (LXWXH)	mm	768X353X490	768X353X490	
Net Weight	kg	22	25.5	
Gross Weight	kg	24	27.5	
Refrigerant		R410A	R410A	
Refrigerant Charge	kg	0.55	0.63	
Connection Pipe	Length	m	5	5
	Gas Additional Charge	g/m	20	15
	Outer Diameter Liquid Pipe	mm	Φ6	Φ6
	Outer Diameter Gas Pipe	mm	Φ9.52	Φ9.52
	Max Distance Height	m	10	10
	Max Distance Length	m	15	15
Note: The connection pipe applies metric diameter.				

The above data is subject to change without notice; please refer to the nameplate of the unit.

Model			GWH12AFB-K3NNA1A	GWH18AFC-K3NNA1A	
Product Code			CA348000600	CA348000700	
Power Supply	Rated Voltage	V~	220-240	220-240	
	Rated Frequency	Hz	50	50	
	Phases		1	1	
Power Supply Mode			Indoor	Indoor	
Cooling Capacity		W	3250	4800	
Heating Capacity		W	3400	5000	
Cooling Power Input		W	1012	1495	
Heating Power Input		W	941	1500	
Cooling Power Current		A	4.32	6.81	
Heating Power Current		A	4.40	6.72	
Rated Input		W	1230	2150	
Rated Current		A	6.3	10.96	
Air Flow Volume(SH/H/M/L/SL)		m ³ /h	550/500/430/330/-	650/560/480/350/-	
Dehumidifying Volume		L/h	1.2	1.8	
EER		W/W	3.21	3.21	
COP		W/W	3.61	3.61	
SEER		W/W	/	/	
HSPF		W/W	/	/	
Application Area		m ²	15-22	21-31	
Indoor Unit	Model of Indoor Unit		GWH12AFB-K3NNA1A/I	GWH18AFC-K3NNA1A/I	
	Product Code of Indoor Unit		CA348N00600	CA348N00700	
	Fan Type		Cross-flow	Cross-flow	
	Diameter Length(DXL)		mm	Φ93X580	Φ98X633
	Fan Motor Cooling Speed(SH/H/M/L/SL)		r/min	1350/1200/1100/850/-	1350/1200/1050/950/-
	Fan Motor Heating Speed(SH/H/M/L/SL)		r/min	1350/1200/1100/900/-	1300/1150/1000/900/-
	Output of Fan Motor		W	20	20
	Fan Motor RLA		A	0.215	0.31
	Fan Motor Capacitor		μF	1	1.5
	Input of Heater		W	/	/
	Evaporator Form			Aluminum Fin-copper Tube	Aluminum Fin-copper Tube
	Pipe Diameter		mm	Φ7.94	Φ7
	Row-fin Gap		mm	1-1.2	2-1.4
	Coil Length (LXDXW)		mm	583X19.05X264	715X25.4X304.8
	Swing Motor Model			MP24AN	MP24HF
	Output of Swing Motor		W	1.5	1.5
	Fuse		A	3.15	3.15
	Sound Pressure Level (SH/H/M/L/SL)		dB (A)	42/39/36/33/-	42/38/34/31/-
	Sound Power Level (SH/H/M/L/SL)		dB (A)	52/49/46/43/-	52/48/44/41/-
	Dimension (WXHXD)		mm	819X256X185	889X294X212
	Dimension of Carton Box (LXWXH)		mm	863X314X249	935X349X273
Dimension of Package (LXWXH)		mm	868X330X260	940X365X284	
Net Weight		kg	8.5	11	
Gross Weight		kg	10	13	

Outdoor Unit	Model of Outdoor Unit		GWH12AAB-K3NNA2A/O	GWH18AAC-K3NNA1A/O
	Product Code of Outdoor Unit		CA115W14100	CA115W14200
	Compressor Manufacturer/Trademark		ZHUHAI LANDA COMPRESSOR CO., LTD	ZHUHAI LANDA COMPRESSOR CO., LTD
	Compressor Model		QXA-B120C150A	QXA-D19F030
	Compressor Oil		RB68EP	ATMOS-RB68EP or equivalent
	Compressor Type		Rotary	Rotary
	L.R.A.	A	26	38.00
	Compressor RLA	A	4.4	7.10
	Compressor Power Input	W	970	1540
	Overload Protector		INTERNAL (UP3-02)	UP3-A6
	Throttling Method		Capillary	Capillary
	Operation Temp	°C	16~30	16~30
	Ambient Temp (Cooling)	°C	18~43	18~48
	Ambient Temp (Heating)	°C	-7~24	-7~24
	Condenser Form		Aluminum Fin-copper Tube	Aluminum Fin-copper Tube
	Pipe Diameter	mm	Φ7.94	Φ7.94
	Rows-fin Gap	mm	1-1.4	2-1.4
	Coil Length (LXD _X W)	mm	697X19.05X506	735X38.1X508
	Fan Motor Speed	rpm	850	850
	Output of Fan Motor	W	35	35
	Fan Motor RLA	A	0.33	0.33
	Fan Motor Capacitor	μF	2.5	2.5
	Air Flow Volume of Outdoor Unit	m ³ /h	1600	1800
	Fan Type		Axial-flow	Axial-flow
	Fan Diameter	mm	Φ394	Φ394.5
	Defrosting Method		Automatic Defrosting	Automatic Defrosting
	Climate Type		T1	T1
	Isolation		I	I
	Moisture Protection		IPX4	IPX4
	Permissible Excessive Operating Pressure for the Discharge Side	MPa	4.3	4.3
	Permissible Excessive Operating Pressure for the Suction Side	MPa	2.5	2.5
Sound Pressure Level (H/M/L)	dB (A)	52/-/-	56/-/-	
Sound Power Level (H/M/L)	dB (A)	62/-/-	66/-/-	
Dimension (WXHXD)	mm	782X540X320	848X540X320	
Dimension of Carton Box (LXWXH)	mm	820X355X580	878X360X580	
Dimension of Package (LXWXH)	mm	823X358X595	881X363X595	
Net Weight	kg	30	39	
Gross Weight	kg	32.5	41.5	
Refrigerant		R410A	R410A	
Refrigerant Charge	kg	0.72	1.26	
Connection Pipe	Length	m	5	5
	Gas Additional Charge	g/m	15	15
	Outer Diameter Liquid Pipe	mm	Φ6	Φ6
	Outer Diameter Gas Pipe	mm	Φ12	Φ12
	Max Distance Height	m	10	10
	Max Distance Length	m	15	25
Note: The connection pipe applies metric diameter.				

The above data is subject to change without notice; please refer to the nameplate of the unit.

Outdoor Unit	Model of Outdoor Unit		GWH12QC-K3NNA1A/O	GWH09AAA-K3NNA1A/O
	Product Code of Outdoor Unit		CA419W00101	CA115W14400
	Compressor Manufacturer/Trademark		ZHUHAI LANDA COMPRESSOR CO., LTD	ZHUHAI LANDA COMPRESSOR CO.,LTD
	Compressor Model		QXA-C133B030gA	QXA-M094T130
	Compressor Oil		RB68EP/FVC 68D	RB68EP or equivalent
	Compressor Type		Rotary	Rotary
	L.R.A.	A	25	18
	Compressor RLA	A	5.17	3.6
	Compressor Power Input	W	1120	772.7
	Overload Protector		Internal	UP3-MC1
	Throttling Method		Capillary	Capillary
	Operation Temp	°C	16~30	16~30
	Ambient Temp (Cooling)	°C	18~43	18~43
	Ambient Temp (Heating)	°C	-7~24	-7~24
	Condenser Form		Aluminum Fin-copper Tube	Aluminum Fin-copper Tube
	Pipe Diameter	mm	Φ7.94	Φ7.94
	Rows-fin Gap	mm	1-1.4	1-1.4
	Coil Length (LXD _X W)	mm	757X19.05X506	658.3X19.05X396
	Fan Motor Speed	rpm	850	320
	Output of Fan Motor	W	30	20
	Fan Motor RLA	A	0.45	0.25
	Fan Motor Capacitor	μF	2	1.5
	Air Flow Volume of Outdoor Unit	m ³ /h	1800	1200
	Fan Type		Axial-flow	Axial-flow
	Fan Diameter	mm	Φ400	Φ320
	Defrosting Method		Automatic Defrosting	Automatic Defrosting
	Climate Type		T1	T1
	Isolation		I	I
	Moisture Protection		IPX4	IPX4
	Permissible Excessive Operating Pressure for the Discharge Side	MPa	4.3	4.3
	Permissible Excessive Operating Pressure for the Suction Side	MPa	2.5	2.5
	Sound Pressure Level (H/M/L)	dB (A)	52/-/-	49/-/-
	Sound Power Level (H/M/L)	dB (A)	62/-/-	59/-/-
Dimension (WXHXD)	mm	848X540X320	720X428X310	
Dimension of Carton Box (LXWXH)	mm	878X360X580	765X350X475	
Dimension of Package (LXWXH)	mm	881X363X595	768X353X490	
Net Weight	kg	33	24.5	
Gross Weight	kg	35.5	26.5	
Refrigerant		R410A	R410A	
Refrigerant Charge	kg	0.8	0.56	
Connection Pipe	Length	m	5	5
	Gas Additional Charge	g/m	20	20
	Outer Diameter Liquid Pipe	mm	Φ6	Φ6
	Outer Diameter Gas Pipe	mm	Φ12	Φ9.52
	Max Distance Height	m	10	10
	Max Distance Length	m	20	15
Note: The connection pipe applies metric diameter.				

The above data is subject to change without notice; please refer to the nameplate of the unit.

Model			GWH24AFD-K3NNA1A	GWH24AFD-K3NNA1A
Product Code			CA348000502	CA348000501
Power Supply	Rated Voltage	V~	220-240	220-240
	Rated Frequency	Hz	50	50
	Phases		1	1
Power Supply Mode			Indoor	Indoor
Cooling Capacity		W	6150	6150
Heating Capacity		W	6700	6700
Cooling Power Input		W	1915	1915
Heating Power Input		W	1856	1856
Cooling Power Current		A	8.49	8.49
Heating Power Current		A	8.23	8.23
Rated Input		W	2700	2700
Rated Current		A	13.88	13.88
Air Flow Volume(SH/H/M/L/SL)		m ³ /h	900/800/700/600/-	900/800/700/600/-
Dehumidifying Volume		L/h	1.8	1.8
EER		W/W	3.21	3.21
COP		W/W	3.61	3.61
SEER		W/W	/	/
HSPF		W/W	/	/
Application Area		m ²	23-34	23-34
Indoor Unit	Model of Indoor Unit		GWH24AFD-K3NNA1A/I	GWH24AFD-K3NNA1A/I
	Product Code of Indoor Unit		CA348N00502	CA348N00500
	Fan Type		Cross-flow	Cross-flow
	Diameter Length(DXL)		mm	Φ106X706
	Fan Motor Cooling Speed(SH/H/M/L/SL)		r/min	1350/1200/1050/900/-
	Fan Motor Heating Speed(SH/H/M/L/SL)		r/min	1350/1200/1100/900/-
	Output of Fan Motor		W	35
	Fan Motor RLA		A	0.35
	Fan Motor Capacitor		μF	2.5
	Input of Heater		W	/
	Evaporator Form			Aluminum Fin-copper Tube
	Pipe Diameter		mm	Φ7
	Row-fin Gap		mm	2-1.4
	Coil Length (LXDXW)		mm	715X25.4X304.8
	Swing Motor Model			MP35CP
	Output of Swing Motor		W	2.5
	Fuse		A	3.15
	Sound Pressure Level (SH/H/M/L/SL)		dB (A)	49/45/41/37/-
	Sound Power Level (SH/H/M/L/SL)		dB (A)	59/55/51/47/-
	Dimension (WXHXD)		mm	1017X304X221
	Dimension of Carton Box (LXWXH)		mm	1077X375X300
	Dimension of Package (LXWXH)		mm	1080X378X315
Net Weight		kg	14	
Gross Weight		kg	17	

Outdoor Unit	Model of Outdoor Unit		GWH24AAD-K3NNA1A/O	GWH24AAD-K3NNA1A/O
	Product Code of Outdoor Unit		CA115W14300	CA115W14301
	Compressor Manufacturer/Trademark		ZHUHAI LANDA COMPRESSOR CO.,LTD	ZHUHAI LANDA COMPRESSOR CO.,LTD
	Compressor Model		QXA-F232F050	QXA-F232F050
	Compressor Oil		RB68EP	RB68EP
	Compressor Type		Rotary	Rotary
	L.R.A.	A	40	40
	Compressor RLA	A	8.4	8.4
	Compressor Power Input	W	1930	1930
	Overload Protector		UP3-27	UP3-27
	Throttling Method		Capillary	Capillary
	Operation Temp	°C	16~30	16~30
	Ambient Temp (Cooling)	°C	18~48	18~48
	Ambient Temp (Heating)	°C	-7~24	-7~24
	Condenser Form		Aluminum Fin-copper Tube	Aluminum Fin-copper Tube
	Pipe Diameter	mm	Φ7	Φ7
	Rows-fin Gap	mm	1-1.4	1-1.4
	Coil Length (LXDXW)	mm	613X38.1X660	613X38.1X660
	Fan Motor Speed	rpm	780	780
	Output of Fan Motor	W	68	68
	Fan Motor RLA	A	0.75	0.75
	Fan Motor Capacitor	μF	2.5	2.5
	Air Flow Volume of Outdoor Unit	m ³ /h	2800	2800
	Fan Type		Axial-flow	Axial-flow
	Fan Diameter	mm	Φ460	Φ460
	Defrosting Method		Automatic Defrosting	Automatic Defrosting
	Climate Type		T1	T1
	Isolation		I	I
	Moisture Protection		IPX4	IPX4
	Permissible Excessive Operating Pressure for the Discharge Side	MPa	4.3	4.3
	Permissible Excessive Operating Pressure for the Suction Side	MPa	2.5	2.5
	Sound Pressure Level (H/M/L)	dB (A)	56/-/-	56/-/-
Sound Power Level (H/M/L)	dB (A)	66/-/-	66/-/-	
Dimension (WXHXD)	mm	931X680X378	931X680X378	
Dimension of Carton Box (LXWXH)	mm	994X428X725	994X428X725	
Dimension of Package (LXWXH)	mm	997X431X740	997X431X740	
Net Weight	kg	50	50	
Gross Weight	kg	54	54	
Refrigerant		R410A	R410A	
Refrigerant Charge	kg	1.45	1.45	
Connection Pipe	Length	m	5	5
	Gas Additional Charge	g/m	15	15
	Outer Diameter Liquid Pipe	mm	Φ6	Φ6
	Outer Diameter Gas Pipe	mm	Φ12	Φ12
	Max Distance Height	m	10	10
	Max Distance Length	m	25	25
Note: The connection pipe applies metric diameter.				

The above data is subject to change without notice; please refer to the nameplate of the unit.

2.2 Capacity Curve in Different Outdoor Temperature

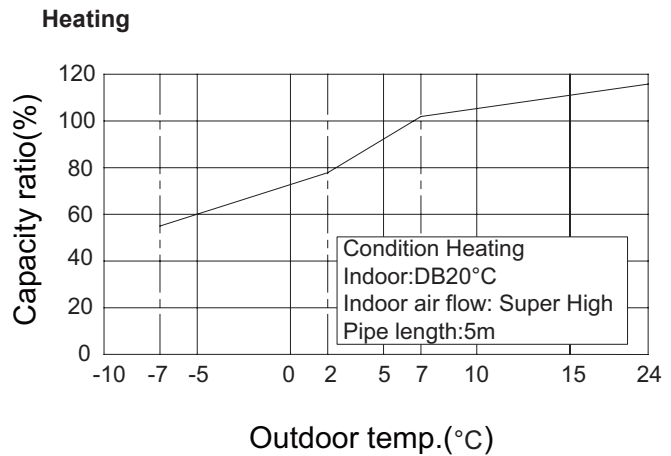
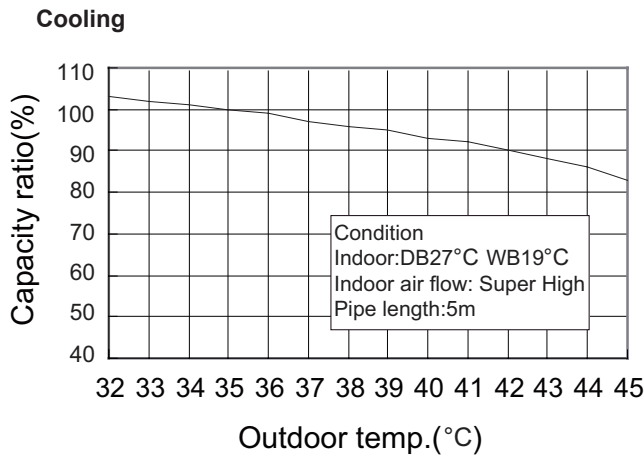

2.3 Cooling and Heating Data Sheet in Rated Frequency

Cooling

Rated cooling condition(°C) (DB/WB)		Model	Pressure of gas pipe connecting indoor and outdoor unit P (MPa)	Inlet and outlet pipe temperature of heat exchanger		Fan speed of indoor unit	Fan speed of outdoor unit
Indoor	Outdoor			T1 (°C)	T2 (°C)		
27/19	35/24	07/09K	0.85~1.0	in:8~11 out:11~14	in:75~85 out:37~43	Super High	High
		12/18/24K		0.9~1.1	in:10~14 out:11~14		

Heating

Rated heating condition(°C) (DB/WB)		Model	Pressure of gas pipe connecting indoor and outdoor unit P (MPa)	Inlet and outlet pipe temperature of heat exchanger		Fan speed of indoor unit	Fan speed of outdoor unit
Indoor	Outdoor			T1 (°C)	T2 (°C)		
20/-	7/6	07/09K	3.5~3.8	in:75~85 out:37~43	in:1~3 out:2~5	Super High	High
		12/18/24K		2.8~3.2	in:55~65 out:25~32		

Instruction:

T1: Inlet and outlet pipe temperature of evaporator

T2: Inlet and outlet pipe temperature of condenser

P: Pressure at the side of big valve

Connection pipe length: 5m.

3. Outline Dimension Diagram

3.1 Indoor Unit

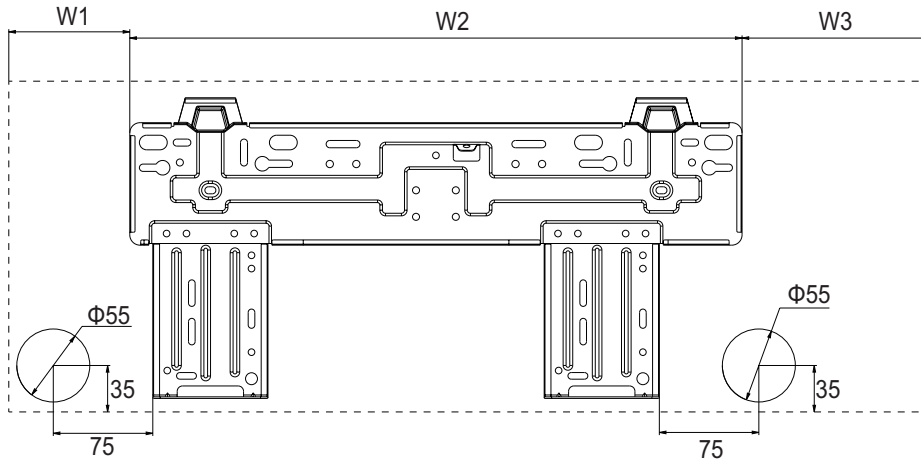
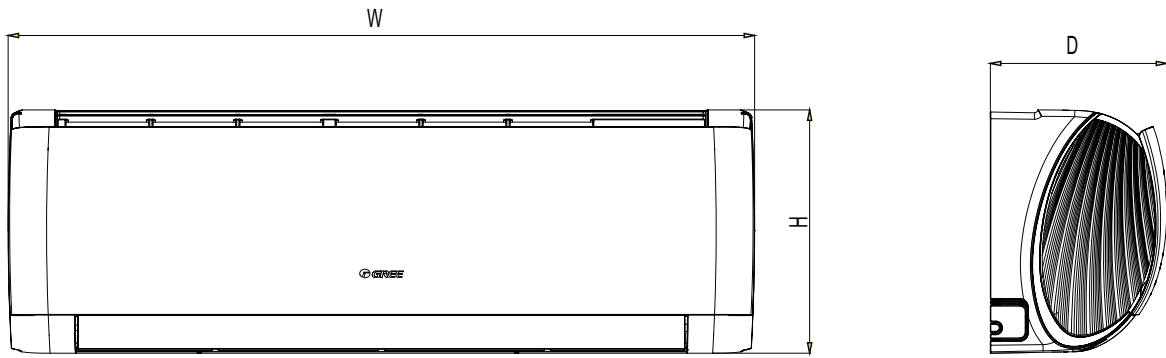

Unit:mm

Models	W	H	D	W1	W2	W3
AFA	744	256	185	116	462	166
AFB	819	256	185	154	462	203
AFC	889	294	211	201	542	146
AFD	1017	304	221	127.5	685	204.5

3.2 Outdoor Unit

GWH07ACA-K3NNA5A/O
GWH09ACB-K3NNA5A/O

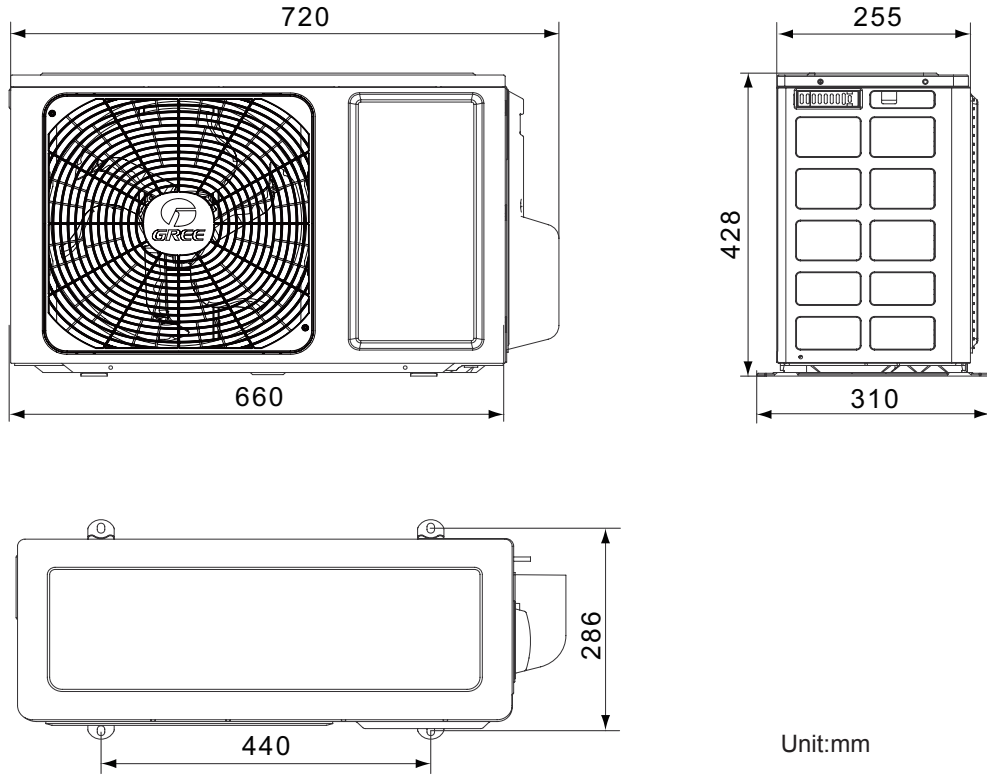

GWH12QC-K3NNA1A/O

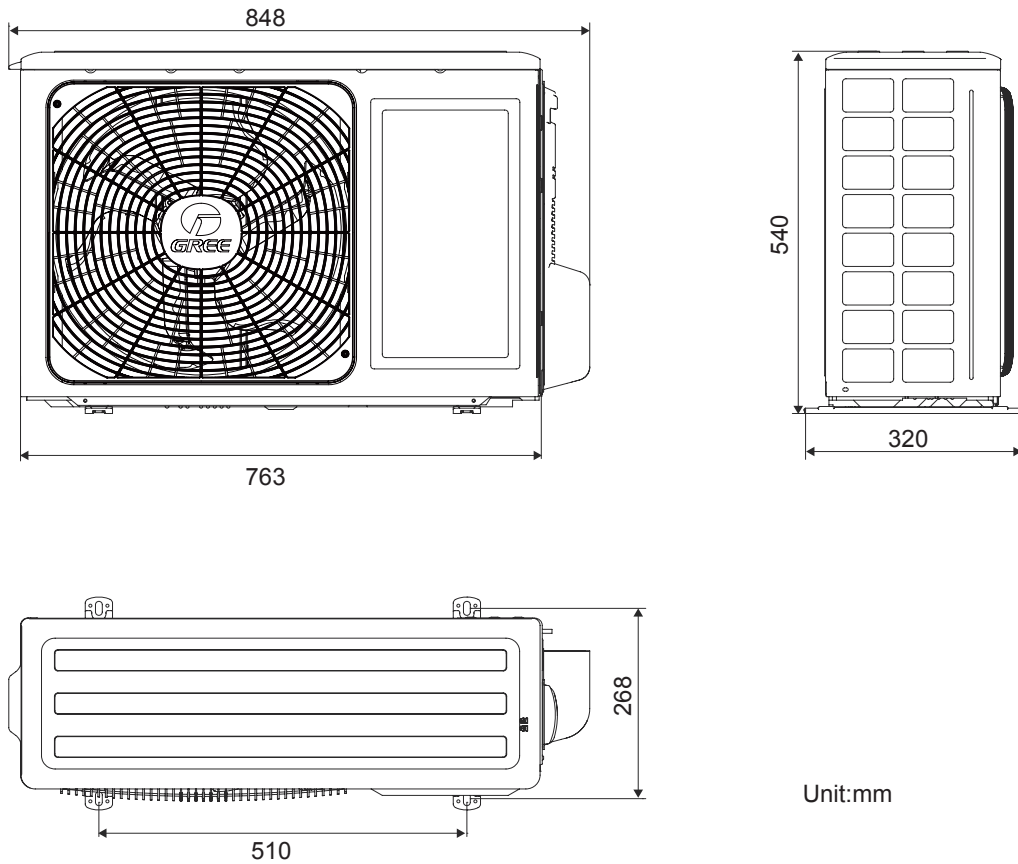

GWH12AAB-K3NNA2A/O

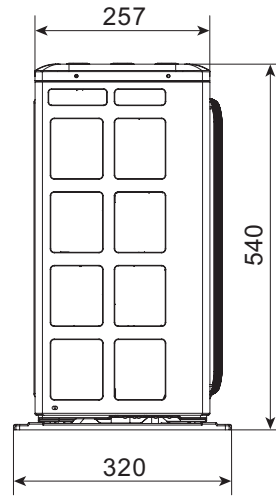
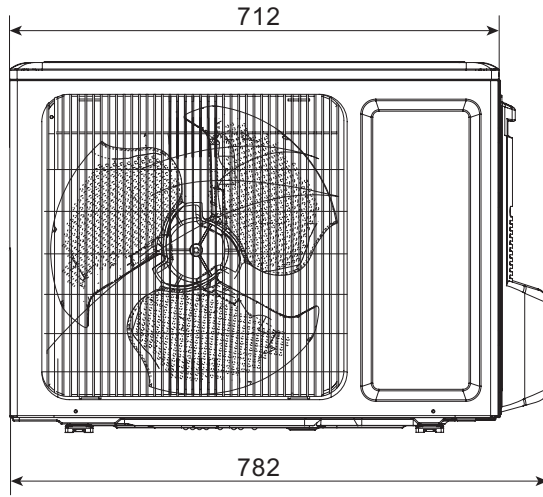

Unit:mm

GWH18AAC-K3NNA1A/O

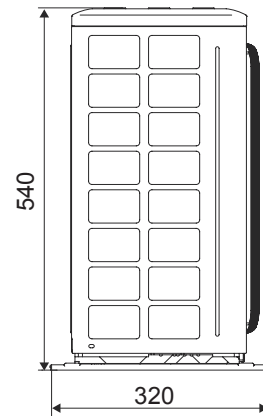
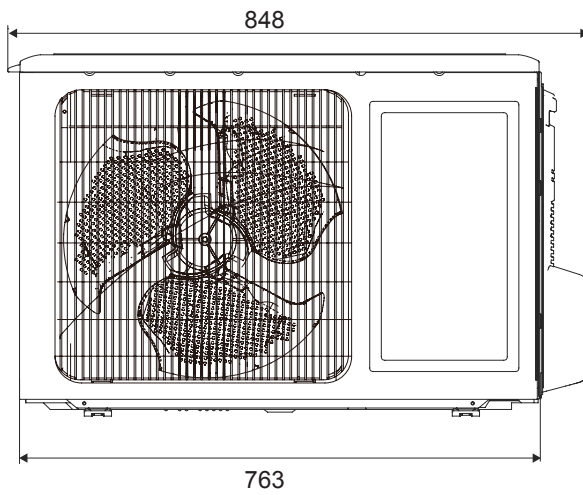

Unit:mm

GWH09AAA-K3NNA1A/O

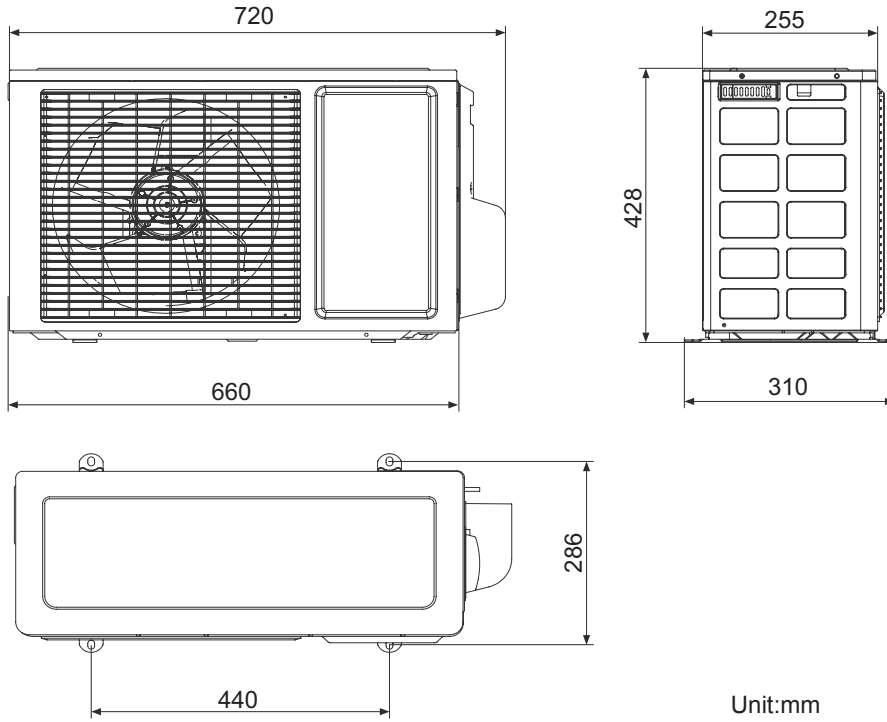

GWH24AAD-K3NNA1A/O(CA115W14300)

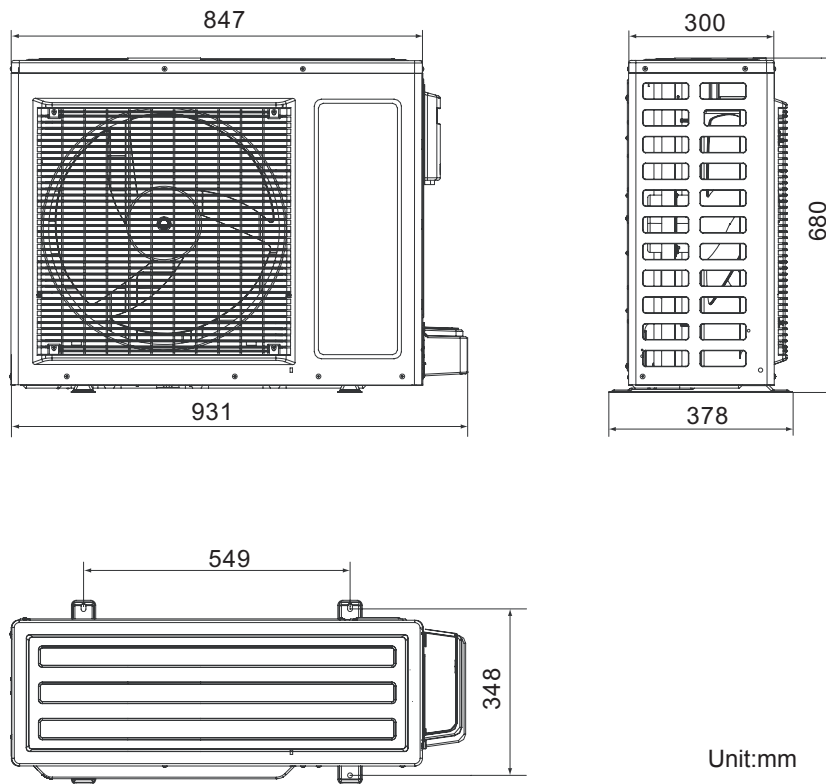

GWH24AAD-K3NNA1A/O(CA115W14301)

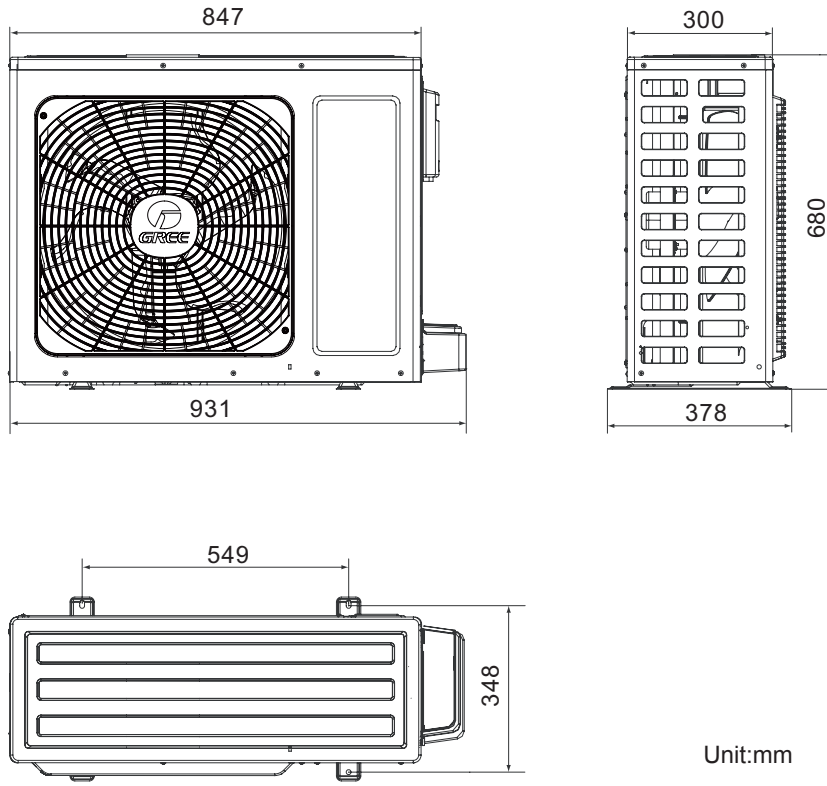

Unit:mm

5. Electrical Part

5.1 Wiring Diagram

● **Instruction**

Symbol	Symbol Color	Symbol	Symbol Color	Symbol	Name
WH	White	GN	Green	CAP	Jumper cap
YE	Yellow	BN	Brown	COMP	Compressor
RD	Red	BU	Blue		Grounding wire
YEGN	Yellow/Green	BK	Black	/	/
VT	Violet	OG	Orange	/	/

Note: Jumper cap is used to determine fan speed and the swing angle of horizontal lover for this model.

● **Indoor Unit**

GWH07AFA-K3NNA1A/I(CA348N00400) GWH09AFB-K3NNA1A/I GWH12AFC-K3NNA1A/I

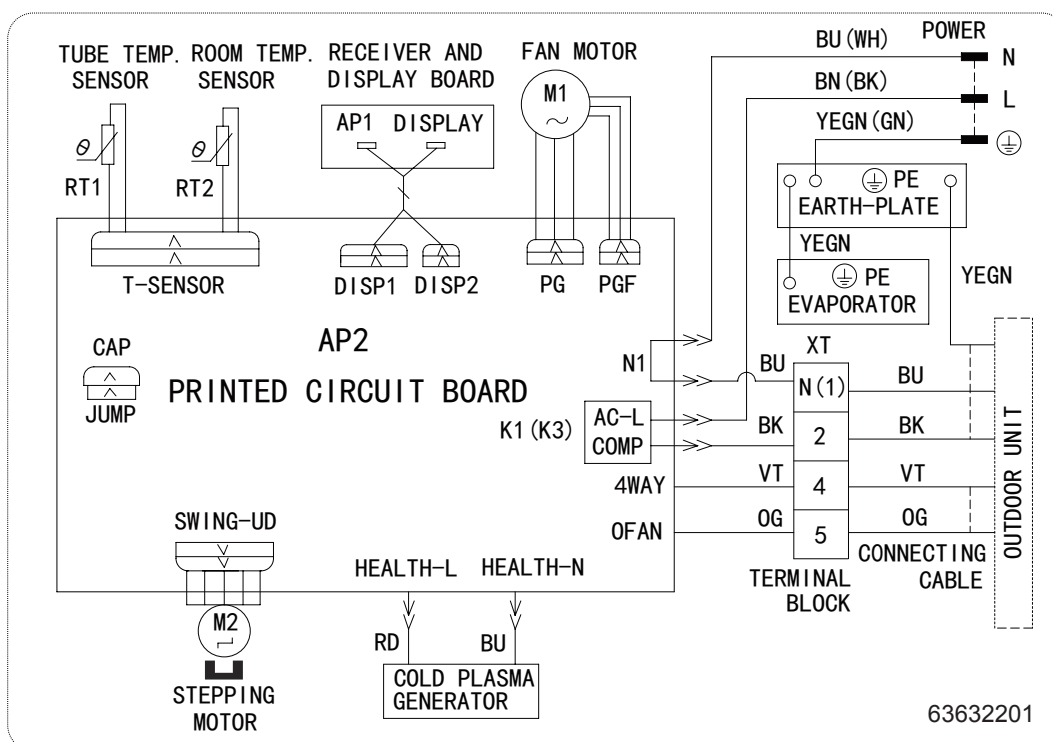

GWH09AFA-K3NNA1A/I GWH12AFB-K3NNA1A/I GWH18AFC-K3NNA1A/I GWH07AFA-K3NNA1A/I(CA348N00401)

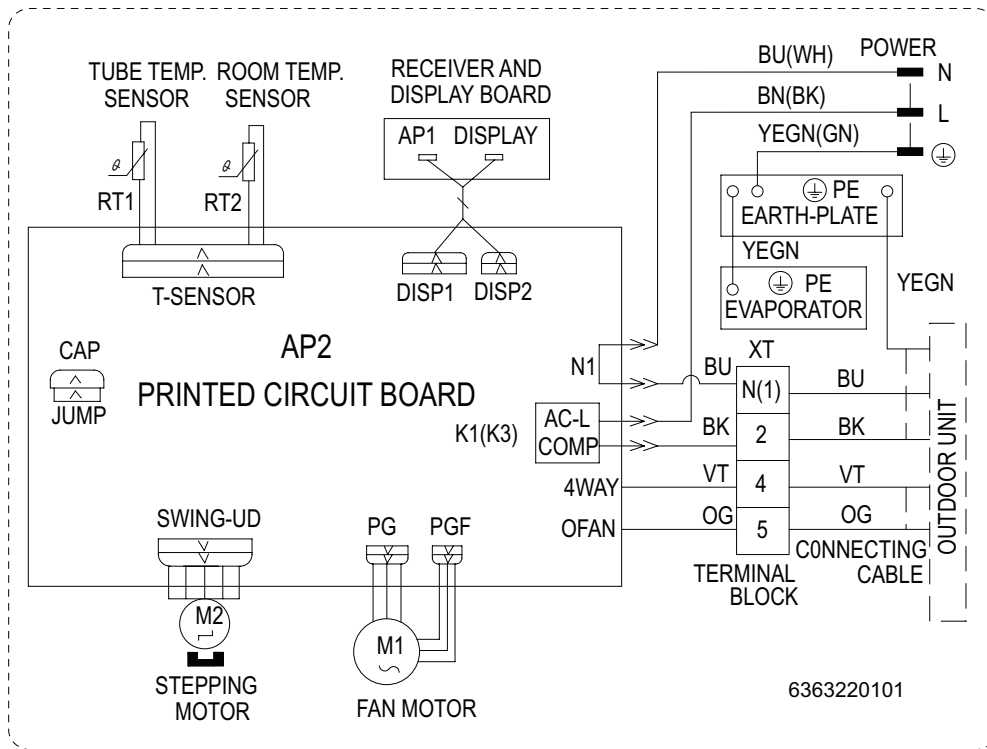

GWH24AFD-K3NNA1A/I (CA348N00502)

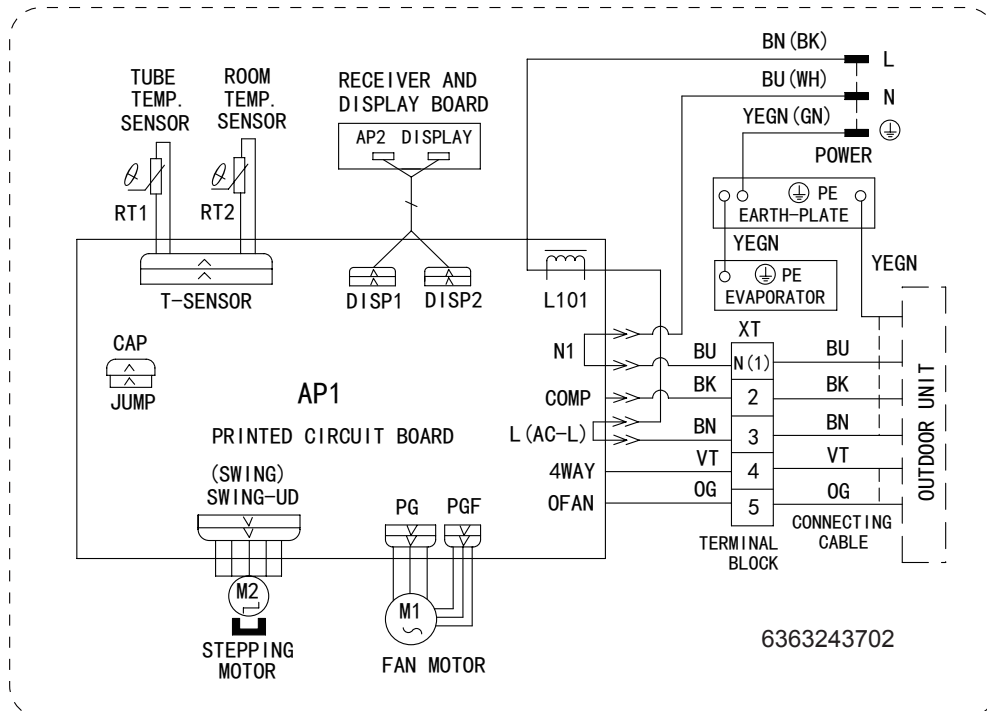

GWH24AFD-K3NNA1A/I (CA348N00500)

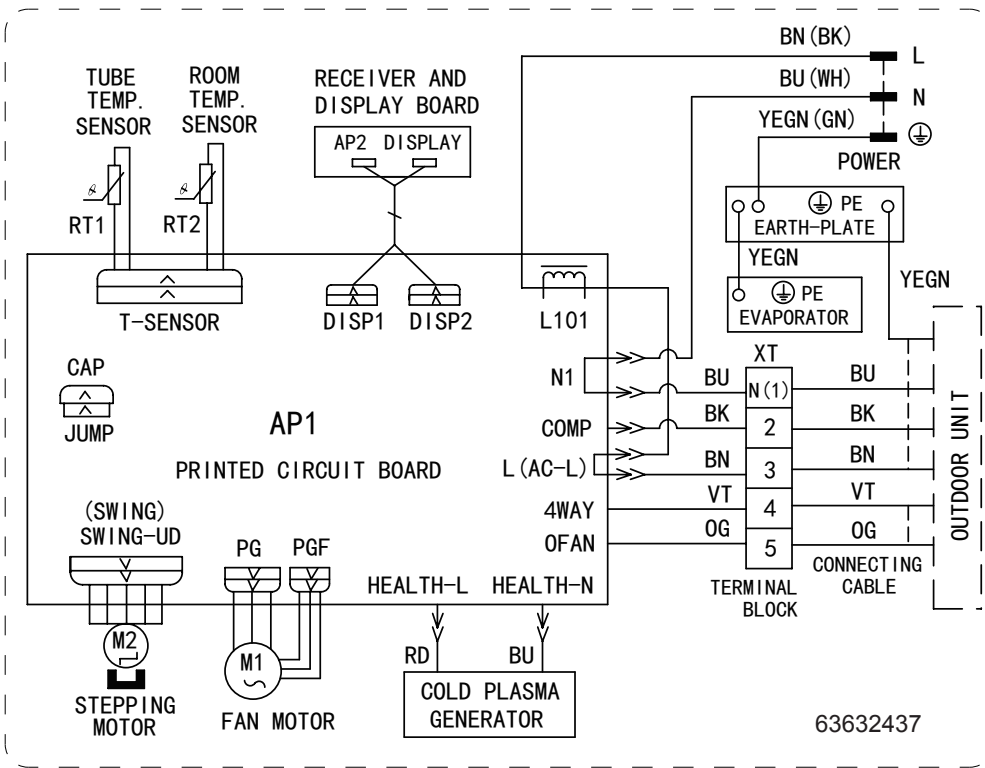

• Outdoor Unit

GWH07ACA-K3NNA5A/O
 GWH09ACB-K3NNA5A/O
 GWH09AAA-K3NNA1A/O
 GWH12QC-K3NNA1A/O
 GWH18AAC-K3NNA1A/O

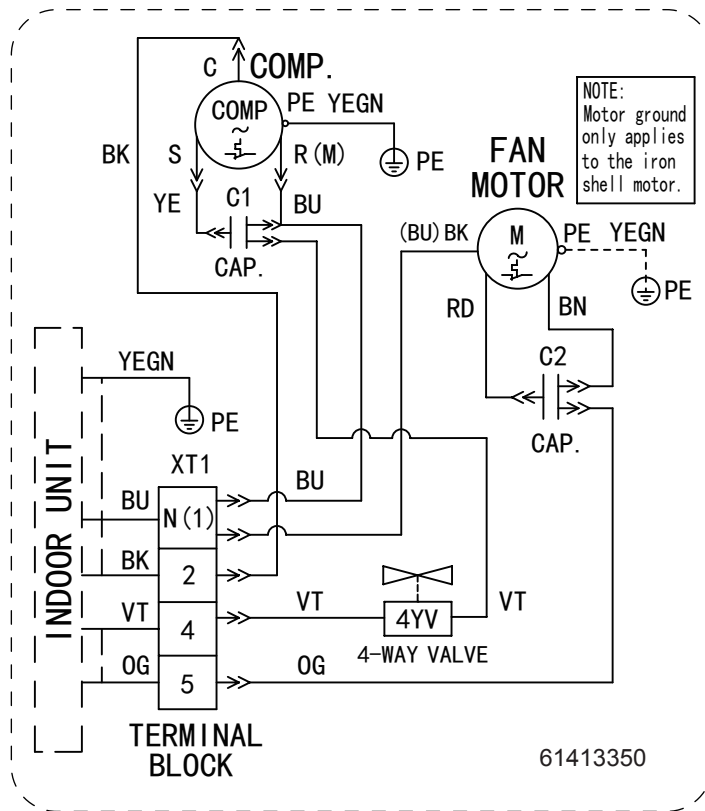

GWH12AAB-K3NNA2A/O

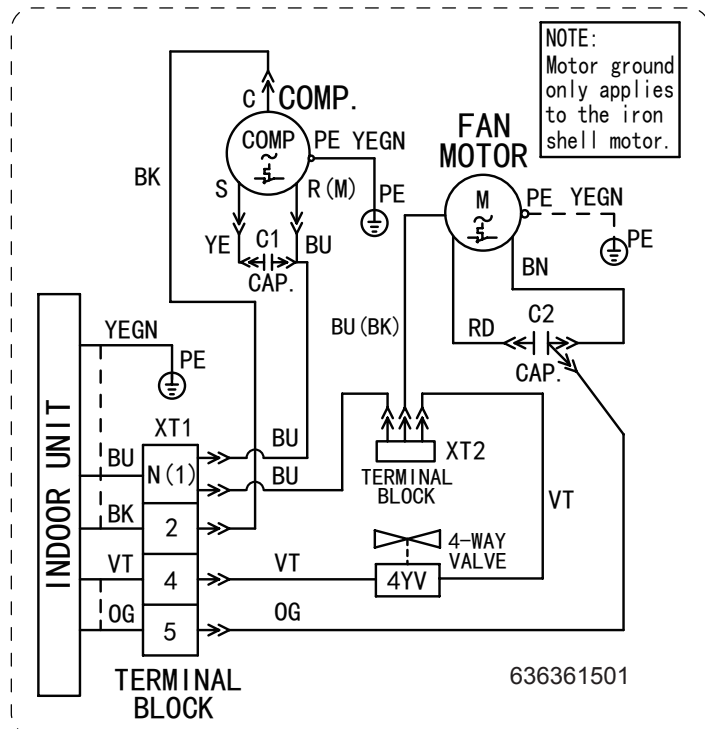

GWH24AAD-K3NNA1A/O(CA115W14300/CA115W14301)

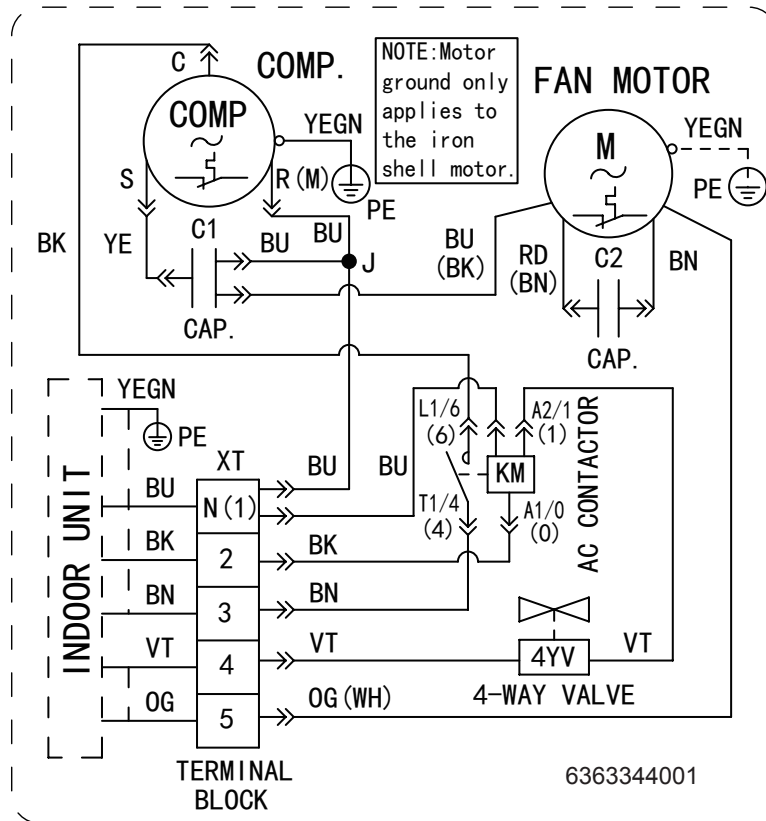

These wiring diagrams are subject to change without notice; please refer to the one supplied with the unit.

5.2 PCB Printed Diagram

07/09K GWH12AFB-K3NNA1A/I

• Top view

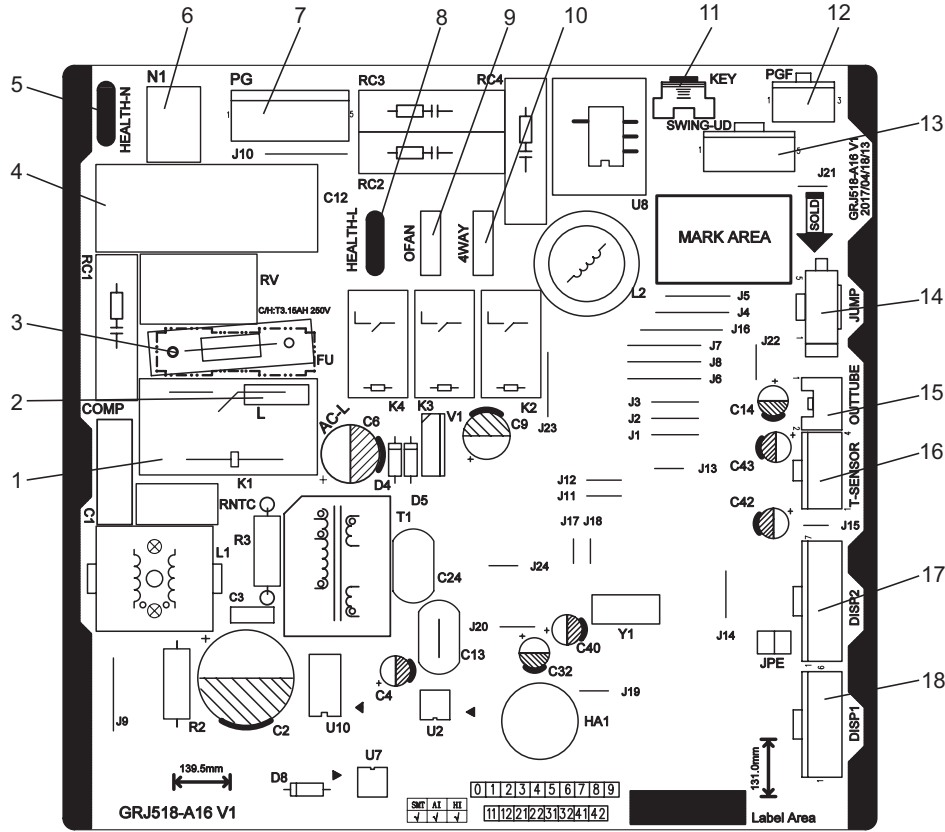

No.	Name
1	Wiring terminal of compressor
2	Terminal of live wire
3	Fuse
4	Fan capacitor
5	Neutral wire terminal of cold plasma
6	Terminal of neutral wire
7	Wiring terminal of PG motor
8	Live wire terminal for cold plasma
9	Wiring terminal of outdoor fan (heat pump unit)
10	Wiring terminal of 4-way valve (heat pump unit)
11	Auto button
12	Feedback wiring terminal of PG motor
13	Wiring terminal of up&down swing motor
14	Jumper cap
15	Wiring terminal of outer tube temperature sensor
16	Wiring terminal of indoor unit temperature sensor
17	Wiring terminal 2 for display receiving board
18	Wiring terminal 1 of display receiving board

• Bottom view

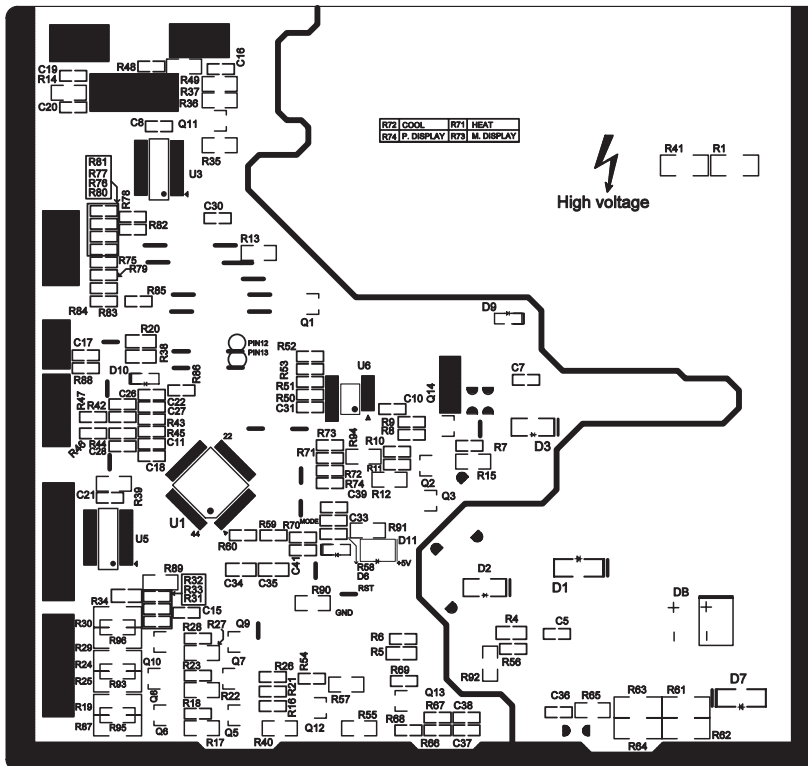

6. Function and Control

6.1 Remote Controller Introduction

Buttons on Remote Controller

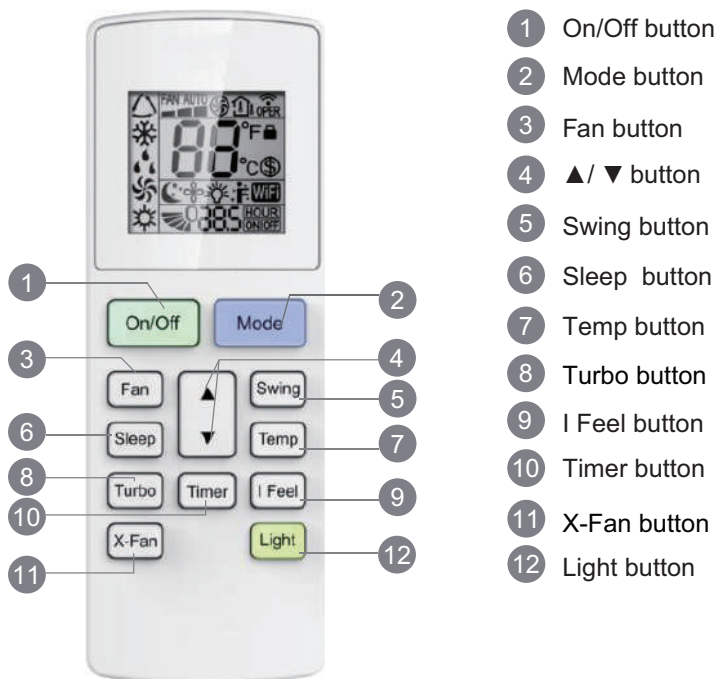

- ① On/Off button
- ② Mode button
- ③ Fan button
- ④ ▲/ ▼ button
- ⑤ Swing button
- ⑥ Sleep button
- ⑦ Temp button
- ⑧ Turbo button
- ⑨ I Feel button
- ⑩ Timer button
- ⑪ X-Fan button
- ⑫ Light button

Icon Display on Remote Controller

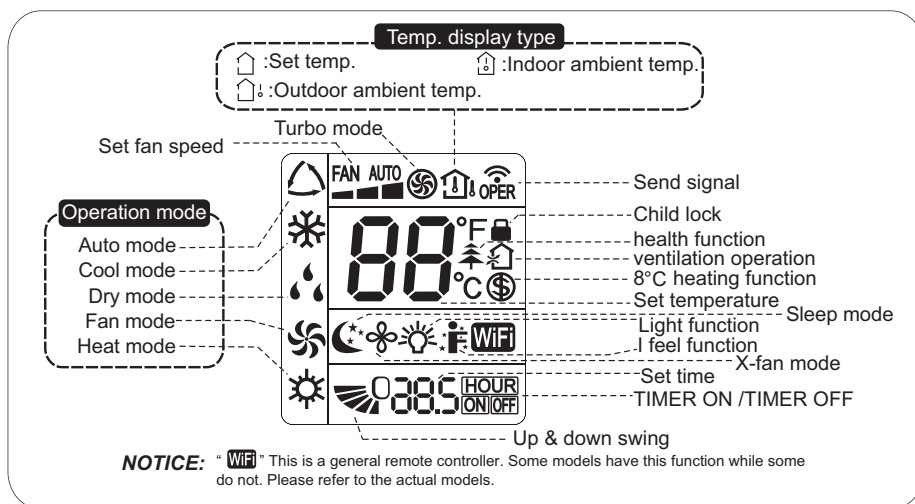

Note:

- This is a general use remote controller, it could be used for the air conditioners with multifunction; For some function, which the model does not have, if you press the corresponding button on the remote controller that the unit will keep the original running status.
- After putting through the power, the air conditioner will give out a sound. Operation indicator "ON" (red indicator, the colour is different for different). After that, you can operate the air conditioner by using remote controller.
- When power is connected (stand by condition), you can operate the air conditioner through the remote controller.
- Under on status, pressing the button on the remote controller, the signal icon "📶" on the display of remote controller will blink once and the air conditioner will give out a "de" sound, which means the signal has been sent to the air conditioner.
- Under off status, set temperature and clock icon will be displayed on the display of remote controller (if timer on, timer off and light functions are set, the corresponding icons will be displayed on the display of remote controller at the same time); Under on status, the display will show the corresponding set function icons.

1. ON/OFF button

Press this button to turn on the unit. Press this button again to turn off the unit.

2. MODE button

Each time you press this button, a mode is selected in a sequence that goes from AUTO, COOL, DRY, FAN, and HEAT *, as the following:



3. FAN Button

This button is used for setting Fan Speed in the sequence that goes from AUTO, , to , then back to Auto.

* Note: Fan speed under dry mode is low speed.

4. ▲ / ▼ button

Press ▲ / ▼ button to increase/decrease set temperature. In AUTO mode, set temperature is not adjustable. When setting Timer On or Timer Off, press "▲" or "▼" button to adjust the time.

5. SWING button

Press this button to set up & down swing angle.

6. SLEEP Button

Under Cool mode, press this button to turn on Sleep function. Press this button to cancel Sleep function. Under Fan and Dry mode, this function is unavailable.

7. TIMER Button

Press this button, you can see indoor set temperature, indoor ambient temperature on indoor unit's display. The setting on remote controller is selected circularly as below:

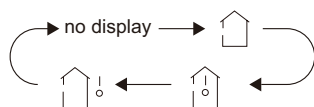

Note:

Outdoor temperature display is not available for some models. At that time, indoor unit receives " " signal, while it displays indoor set temperature.

8. Turbo button

Under COOL or HEAT mode, press this button to activate / deactivate the Turbo function.

Note:

Not applicable for this unit.

9. I FEEL button

Press this button to start I FEEL function and " " will be displayed on the remote controller. After this function is set, the remote controller will send the detected ambient temperature to the controller and the unit will automatically adjust the indoor temperature according to the detected temperature. Press this button again to close I FEEL function and " " will disappear. When I FEEL function is turned on, the remote controller should be put within the area where indoor unit can receive the signal sent by the remote controller.

10. Timer button

- Under ON status, press this button to set timer OFF; Under OFF status, press this button to set timer ON.
- Press this button once and the characters of HOUR ON (OFF) will flash to be displayed. Meanwhile, press " ▲ " button or " ▼ " button to adjust timer setting (time will change quickly if holding " ▲ " or " ▼ " button). Time setting range is 0.5~24hours. Press this button again to confirm timer setting and the characters of HOUR ON (OFF) will stop flashing. If the characters are flashing but you haven't press timer button, timer setting status will be quit after 5s. If timer is confirmed, press this button again to cancel timer.

11.X-Fan button



- Press this button in COOL or DRY mode to turn on X-fan function.

When this function is started up, indoor fan will still operate at low fan speed for a while after turning off the unit by remote controller.

12.Light button

Press this button to turn on the display's light and press this button again to turn off the display's light.

Combination of " ▲ " and " ▼ " buttons: About lock

Press " ▲ " and " ▼ " buttons simultaneously 3s to lock or unlock the keypad. If the remote controller is locked,  is displayed. In this case, pressing any button,  blinks three times.

Combination of "MODE" and " ▼ " buttons: About switch between Fahrenheit and centigrade

At unit OFF, press " MODE " and " ▼ " buttons simultaneously to switch between ℃ and ℉.

Replacement of Batteries in Remote Controller

1. Press the back side of remote controller marked with "" , as shown in the fig, and then push out the cover of battery box along the arrow direction.
2. Replace two 7# (AAA 1.5V) dry batteries, and make sure the position of "+" polar and "-" polar are correct.
3. Reinstall the cover of battery box.

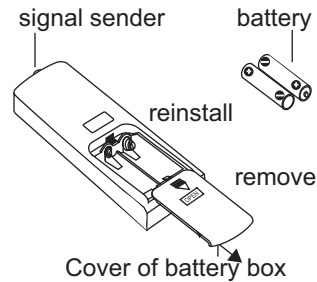

Note:

- During operation, point the remote control signal sender at the receiving window on indoor unit.
- The distance between signal sender and receiving window should be no more than 6m, and there should be no obstacles between them.
- Signal may be interfered easily in the room where there is fluorescent lamp or wireless telephone; remote controller should be close to indoor unit during operation.
- Replace new batteries of the same model when replacement is required.
- When you don't use remote controller for a long time, please take out the batteries.
- If the display on remote controller is fuzzy or there's no display, please replace batteries.

6.2 Brief Description of Modes and Functions

1. Summary

(1) Buzzer

When the controller is energized or receives signal from button (emergency operation switch on air conditioner) or remote controller, the buzzer will give out a beep.

(2) Display

After energization, all icons will be displayed once. Operation icon is in red under standby status. After turning on the unit by remote controller, operation icon is bright and corresponding set operation mode icon will be displayed (Mode icon include: cooling, heating, drying).

(3) Temperature parameter

- ◆ Indoor set temperature (T_{preset})
- ◆ Indoor ambient temperature ($T_{\text{amb.}}$)
- ◆ Inner tube temperature of indoor evaporator (T_{tube})

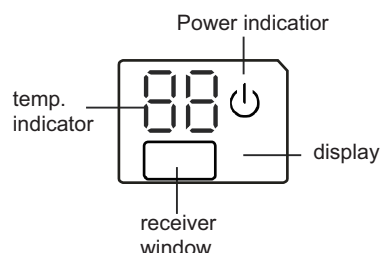

2. Introduction of Basic Mode Function

- ◆ Once the compressor is energized, there should be a minimum interval of 3 mins between two start-ups.
 - ◆ If the unit is with memory function and is off before power failure, the compressor can be restarted without an interval of 3 mins; if the unit is on before power failure, the compressor will be restarted with an interval of 3 mins.
- Once compressor is started, it won't stop within 6 mins according to the change of room temp.

(1) Auto mode

① Operation condition and process for auto mode

Under auto mode, the system will automatically select operation mode (cooling, heating, and fan) according to indoor ambient temperature. There will be 30s delayed for protection between mode switchover.

- ◆ When $T_{\text{amb.}} \geq 26^{\circ}\text{C}$, the system operates under cooling mode; Ex-factory set temperature is 20°C .
- ◆ Heat pump unit: when $T_{\text{amb.}} \geq 22^{\circ}\text{C}$, the system operates under heating mode; Ex-factory set temperature is 25°C .
- ◆ $22^{\circ}\text{C} < T_{\text{amb.}} < 26^{\circ}\text{C}$: The system operates under fan mode if turn on the unit to enter into auto mode for the first time; If switch to auto mode from cooling, heating or fan mode, the system keeps previous operation mode; If switch to auto mode from drying mode, the system operates under fan mode.

② Display: Operation icon, actual operation mode icon, set temperature (that's the display content of dual-8 nixie tube)

③ Protection function is same as that under each mode.

(2) Cooling mode

① Operation condition and process for cooling mode

- ◆ When $T_{\text{amb.}} \geq T_{\text{set}} + 1^{\circ}\text{C}$, the system operates under cooling mode. In this case, the compressor, the ODU fan motor and the IDU fan motor operates at set speed.
- ◆ When $T_{\text{amb.}} \leq T_{\text{set}} - 1^{\circ}\text{C}$, the compressor and the ODU fan motor stop, while the IDU fan motor operates at set speed.
- ◆ When $T_{\text{set}} - 1^{\circ}\text{C} < T_{\text{amb.}} < T_{\text{set}} + 1^{\circ}\text{C}$, the system will maintain its previous operation status.

In cooling mode, the 4-way valve is de-energized (4-way valve is not available for cooling only unit). Temperature setting range is $16 \sim 30^{\circ}\text{C}$.

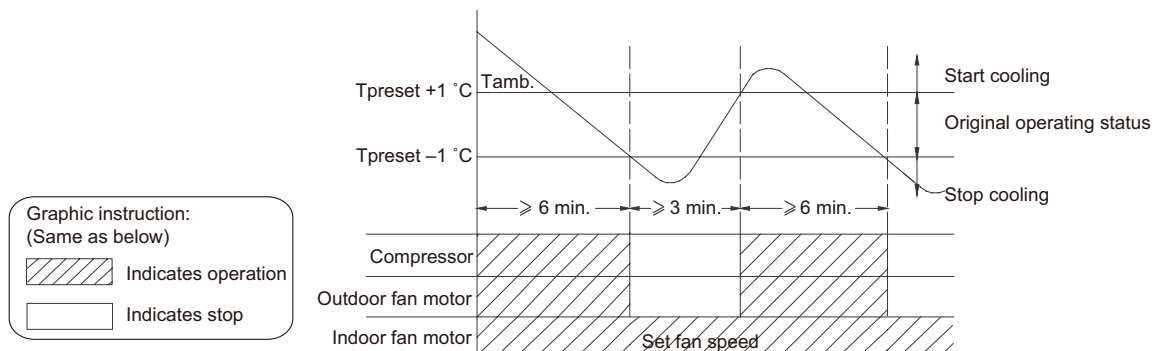

② Display: Operation icon, cooling icon, set temperature.

③ Protection function

- ◆ Freeze protection

During operation, when controller detected that $T_{\text{tube}} \leq 0^{\circ}\text{C}$ for a consecutive period of time, the system enters into freeze protection. In that case, the compressor and the ODU fan stop operation, while the IDU operates at set fan speed. If freeze protection is released and

the compressor has been out of operation for 3 mins, the unit will resume its previous operation status.

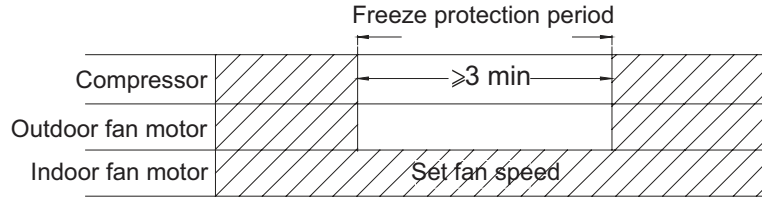

◆ Overcurrent protection (this protection function is not available for those models whose cooling capacity $\leq 12000\text{Btu/h}$)

During operation process, if controller detected that system current exceeds the limit value for 3s consecutively (overcurrent), only the fan operates. About 3 mins later, if overcurrent is released, the system will resume original operation.

If overcurrent protection occurs for 6 times consecutively, and resume operation time won't exceed 6min every time, overcurrent protection information will be displayed. After turning off the unit, display won't be displayed.

If turn on the unit again, the system will be restated up again. Overcurrent protection information will be eliminated.

Please refer to maintenance part for display information and disposal method for details.

◆ Locked protection to IDU fan motor

During operation of IDU fan motor, if controller detected that the rotation speed of IDU fan motor less than 300/min or stop rotation, the motor operates abnormally. In order to prevent damage to motor, controller will protect automatically, the system stops operation and blocked information of IDU fan motor will be displayed. After turning off the unit, display won't be displayed.

If turn on the unit again, the system will be restated up again. Blocked information of IDU fan motor will be eliminated. (For some models, they can only be restated up after re-energized)

Please refer to maintenance part for display information and disposal method for details.

(3) Drying mode

① Operation condition and process for drying mode

◆ When $T_{amb.} > T_{set} + 2^{\circ}\text{C}$, the system starts drying and cooling. In this case, the compressor and the ODU fan motor operate, and the IDU fan motor operates at low speed.

◆ When $T_{set} - 2^{\circ}\text{C} \leq T_{amb.} \leq T_{set} + 2^{\circ}\text{C}$, the system will start drying. In this case, the IDU fan motor operates at low speed; the compressor and the ODU fan motor operate for 6 minutes and stop for 4 minutes in cycle.

◆ When $T_{amb.} < T_{set} - 2^{\circ}\text{C}$, the compressor and the ODU fan motor stop, while the IDU fan motor runs at low speed.

In drying mode, the 4-way valve is de-energized (4-way valve is not available for cooling only unit); Temperature setting range is $16\sim 30^{\circ}\text{C}$. Fan speed can't be adjusted.

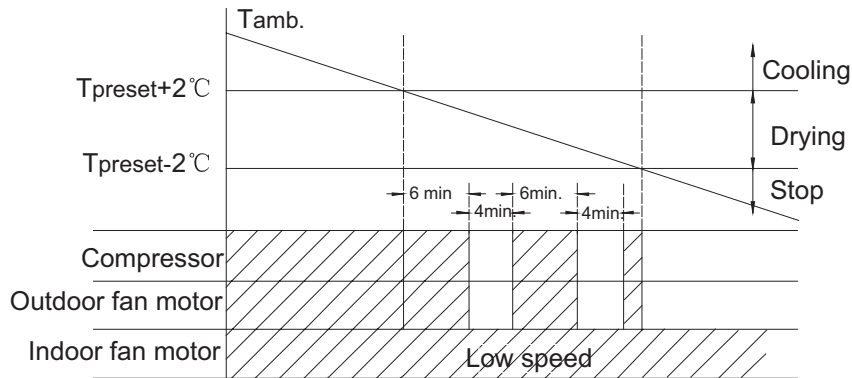

② Display: Operation icon, drying icon, set temperature.

③ Protection function

◆ Freeze protection

During drying and cooling operation, when the controller detected that $T_{tube} \leq 0^{\circ}\text{C}$ for a period of time consecutively, the system will enter into freeze protection. In that case, the compressor and the ODU fan motor stops operation, while the IDU fan motor operates at low speed. When freeze protection is release and the compressor has stopped for 3min, the system will resume original operation.

During drying operation, when the controller detected that $T_{tube} \leq 0^{\circ}\text{C}$ for a period of time consecutively, the system enters into freeze protection. In that case, the compressor, the ODU fan motor stops operation, while the IDU fan motor operates at low speed. When freeze protection is release and the compressor has stopped for 4min, the system will resume original operation.

◆ Other protection is same as that under cooling mode.

(4) Fan mode

① Operation condition and process for fan mode

In fan mode, the IDU fan motor operates at set speed, while the compressor and the ODU fan motor stop. 4-way valve is de-energized (4-way valve is not available for cooling only unit). Temperature setting range is 16~30°C .

② Display: Operation icon, set temperature.

③ Protection function

In fan mode, there are overcurrent protection and blocked protection of IDU fan motor. Please refer to corresponding protection function under cooling mode for details.

(5) Heating mode(no heating mode is not available for cooling only unit)

① Operation conditioner and process for heating mode

◆ When $T_{amb.} - T_{supplementary} \leq T_{set} - 1^{\circ}\text{C}$, the unit starts heating operation. In this case, the 4-way valve, compressor and ODU fan motor run simultaneously; the IDU fan motor will run after a while to prevent blowing cold air.

◆ When $T_{amb.} - T_{supplementary} \geq T_{set} + 1^{\circ}\text{C}$, the compressor and ODU fan motor stop; the 4-way valve remains energized; the IDU fan motor blows residual heat for a while in set speed.

◆ When $T_{set} - 1^{\circ}\text{C} < T_{amb.} - T_{supplementary} < T_{set} + 1^{\circ}\text{C}$, the unit will maintain its previous running status.

In heating mode, 4-way valve is energized. Temperature setting range is 16~30°C .

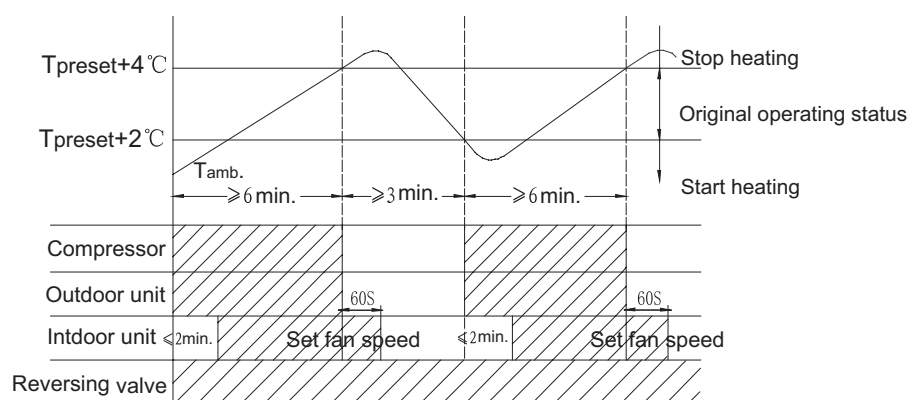

② Display: Operation icon, heating icon, set temperature.

③ Defrosting condition and process

For ensuring heating effect, air conditioner will defrost automatically according to defrosting status on outdoor unit. During defrosting, the heating icon is on for a while and then extinguish.

④ Protection function

◆ Overheating prevention protection

During operation, if the controller detects that $T_{tube} \geq 55^{\circ}\text{C}$ or 56°C , the ODU fan motor stops operation; When T_{tube} returns to normal, fan motor resumes operation.

◆ Noise silencing protection

When turning off the unit or during mode switchover, the 4-way valve is closed. In order to decrease noise, the 4-way valve will delay 2mins to be closed.

◆ Overcurrent protection (this protection function is not available for those models whose cooling capacity $\leq 12000\text{Btu/h}$)

During operation process, if controller detected that system current exceeds the limit value for 3s consecutively(overcurrent), the system stops operation. About 3mins later, if overcurrent is released, the system will resume original operation. If overcurrent protection occurs for 6 times consecutively, and resume operation time won't exceed 6min every time, overcurrent protection information will be displayed. After turning off the unit, display won't be displayed.

If turn on the unit again, the system will be restated up again. Overcurrent protection information will be eliminated.

Please refer to maintenance part for display information and disposal method for details.

◆ Locked protection to IDU fan motor

During operation of IDU fan motor, if controller detected that the rotation speed of IDU fan motor less than 300/min or stop rotation, the motor operates abnormally. In order to prevent damage to motor, controller will protect automatically, the system stops operation and blocked information of IDU fan motor will be displayed. After turning off the unit, display won't be displayed.

If turn on the unit again, the system will be restated up again. Blocked information of IDU fan motor will be eliminated. (For some models, they can only be restated up after re-energized)

Please refer to maintenance part for display information and disposal method for details.

3. Other Control Function Introduction

(1) Timer function

Controller has general timer function and clock timer function. When you select the remote controller with general timer function, only the general timer function of controller can be activated; when you select the remote controller with clock timer, only the clock timer function of controller can be activated.

- ① General timer: The precision of general timer is 0.5hour. 24hours circulated timer can't be set.
 - ◆ Timer ON: Timer ON can be set at unit OFF. If selected ON time is reached, the unit will start to operate according to previous setting status. Time setting range is 0.5~24hr in 30-minute increments.
 - ◆ Timer OFF: Timer OFF can be set at unit ON. If selected OFF time is reached, the unit will stop. Time setting range is 0.5~24hr in 30-minute increments.
- ② Clock timer: The precision of clock timer is 0.5hour. 24hours circulated timer can be set.
 - ◆ Timer ON: If timer ON is set during operation of the unit, the unit will continue to operate. If timer ON is set at unit OFF, upon ON time reaches, the unit will start to run according to previous setting status.
 - ◆ Timer OFF: If timer OFF is set at unit OFF, the system will keep standby status. If timer OFF is set at unit ON, upon OFF time reaches, the unit will stop operation.

- ◆ Timer change:

Although timer has been set, the unit still can be turned on/off by pressing ON/OFF button on the remote controller. You can also reset the timer.

If timer ON and timer OFF are set at the same time during operation of the unit, the unit will keep running at current status till OFF time reaches. Upon ON time reached, the system will be turned on automatically. The unit will operate circularly like that every 24hours.

If timer ON and timer OFF are set at unit OFF status, the system keep OFF status till ON time reaches. Upon OFF time reaches, the system will be turned OFF automatically. The unit will operate circularly like that every 24hours.

(2) Emergency operation switch

After pressing this button, the system will operate according under auto mode and the IDU fan motor operates at auto speed. Swing motor operates when the IDU fan motor operates. Press this button again to turn off the unit.



(3) Sleep function

In this mode, the system will select proper sleep curve to operate according to different set temperature.

- ① If start up sleep function under cooling or drying mode, the system will increase set temperature automatically within a certain range to operate.
- ② If start up sleep function under heating mode, the system will decrease set temperature automatically within a certain range to operate.

(4) Turbo function

Turbo function can be set under cooling and heating modes. During operation of turbo function, the system operates at the maximum fan speed.

(5) Dry function

Dry function can be set under cooling and drying modes. During operation of drying function, the fan will stop operation after operating for a period of time when turning off the unit.

(6) Auto fan speed control

Auto fan speed control can be set under cooling, heating and fan mode. During operation of auto fan speed control, the IDU fan motor will adjust the fan speed (high, medium or low speed) according to ambient temperature.

(7) Up&down swing control

- ① After energization, up & down swing motor will firstly have the horizontal louver rotate anticlockwise to position O to close air outlet. If swing function has not been set after start-up of the unit, horizontal louver will turn clockwise to position D in heating mode, or turn clockwise to level position L in other modes.
- ② If swing function is set when turning on the unit, the horizontal louver will swing between L and D. Horizontal louver has 7 swing statuses:

- ◆ Stay at position L: control by remote controller:
- ◆ Stay at position A: control by remote controller:
- ◆ Stay at position B: control by remote controller:
- ◆ Stay at position C: control by remote controller:
- ◆ Stay at position D: control by remote controller:
- ◆ Swing between L and D: control by remote controller:
- ◆ Stop at any position between L and D (angles between L and D are equiangular) and no display on remote controller.

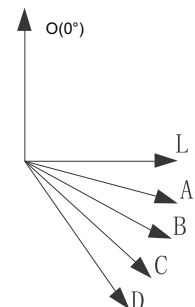

- ③ When turning off the unit, horizontal louver will close at position O.
- ④ Swing action is valid only when set swing command and the IDU fan motor is operating.

(8) Dual-8 nixie tube display

- ◆ When the air conditioner is turned on for the first time, dual-8 nixie tube defaulted to display current set temperature.
- ◆ When controller receives signal of display set temperature, dual-8 nixie tube displays set temperature. When received remote control signal is switched to indoor ambient temperature display status signal from other display status, dual-8 nixie tube will display indoor ambient temperature for 3-5s, and then turn back to display set temperature. If remote control to set other status, the display keeps the same.
- ◆ When air conditioner has a malfunction, dual-8 nixie tube will show relevant error code.

F1	Indoor ambient temperature sensor is open/short-circuited
F2	Indoor evaporator temperature sensor is open/short-circuited
H6	Blocked protection of IDU fan motor
C5	Malfunction protection of jumper cap
U8	Zero-crossing inspection circuit malfunction of the IDU fan motor
F0	Lack of refrigerant or block protection for the system
E8	Overload malfunction
E1	High pressure protection
E5	Overcurrent protection
H3	Overload protection compressor

- ◆ When air conditioner is in auto defrosting, the heating icon will be on for a while and then extinguish. No display for some models without mode indicator.
- ◆ If turn off light button, all display will be turned off.

(9) Memory function

- ① Power failure when turning on the unit
 - ◆ Memory content: ON status, mode, up&down swing, light, set temperature, set fan speed, general timer, Fahrenheit/ Celsius
 - ◆ General timer can be memorized. Time of timer is calculated again from energization.
 - ◆ Clock timer can't be memorized.
- ② Power failure when turning off the unit
 - ◆ Memory content: OFF status, mode, up&down swing, light, set temperature, set fan speed, general timer, Fahrenheit/ Celsius
 - ◆ General timer can be memorized. Time of timer is calculated again from energization.
 - ◆ Clock timer can't be memorized.

4. Special Function

(1) Health function (for the model with health function)

During operation of the IDU fan motor, press health button on the remote controller to start health function (If there is not health button on the remote controller, the unit defaults health function ON).

(2) I Feel function (for all models, but it needs the remote controller which can set this function)

When I FEEL command is received, the controller will operate according to the ambient temperature sent by the remote controller (For defrosting and cold air prevention, the unit operates according to the ambient temperature sensed by the air conditioner). The remote controller will regularly send ambient temperature data to the controller. When the data has not been received for a long time, the unit will operate according to the temperature sensed by the air conditioner. If I FEEL function is not set, the ambient temperature will be that sensed by the air conditioner.

Part II : Installation and Maintenance

7. Notes for Installation and Maintenance

Safety Precautions: Important!

Please read the safety precautions carefully before installation and maintenance.

The following contents are very important for installation and maintenance.

Please follow the instructions below.

- The installation or maintenance must accord with the instructions.
- Comply with all national electrical codes and local electrical codes.
- Pay attention to the warnings and cautions in this manual.
- All installation and maintenance shall be performed by distributor or qualified person.
- All electric work must be performed by a licensed technician according to local regulations and the instructions given in this manual.
- Be caution during installation and maintenance. Prohibit incorrect operation to prevent electric shock, casualty and other accidents.



Warnings

Electrical Safety Precautions:

1. Cut off the power supply of air conditioner before checking and maintenance.
2. The air condition must apply specialized circuit and prohibit share the same circuit with other appliances.
3. The air conditioner should be installed in suitable location and ensure the power plug is touchable.
4. Make sure each wiring terminal is connected firmly during installation and maintenance.
5. Have the unit adequately grounded. The grounding wire cant be used for other purposes.
6. Must apply protective accessories such as protective boards, cable-cross loop and wire clip.
7. The live wire, neutral wire and grounding wire of power supply must be corresponding to the live wire, neutral wire and grounding wire of the air conditioner.
8. The power cord and power connection wires cant be pressed by hard objects.
9. If power cord or connection wire is broken, it must be replaced by a qualified person.

10. If the power cord or connection wire is not long enough, please get the specialized power cord or connection wire from the manufacture or distributor. Prohibit prolong the wire by yourself.

11. For the air conditioner without plug, an air switch must be installed in the circuit. The air switch should be all-pole parting and the contact parting distance should be more than 3mm.

12. Make sure all wires and pipes are connected properly and the valves are opened before energizing.

13. Check if there is electric leakage on the unit body. If yes, please eliminate the electric leakage.

14. Replace the fuse with a new one of the same specification if it is burnt down; dont replace it with a cooper wire or conducting wire.

15. If the unit is to be installed in a humid place, the circuit breaker must be installed.

Installation Safety Precautions:

1. Select the installation location according to the requirement of this manual.(See the requirements in installation part)
2. Handle unit transportation with care; the unit should not be carried by only one person if it is more than 20kg.
3. When installing the indoor unit and outdoor unit, a sufficient fixing bolt must be installed; make sure the installation support is firm.
4. Ware safety belt if the height of working is above 2m.
5. Use equipped components or appointed components during installation.
6. Make sure no foreign objects are left in the unit after finishing installation.

Refrigerant Safety Precautions:

1. Avoid contact between refrigerant and fire as it generates poisonous gas; Prohibit prolong the connection pipe by welding.
2. Apply specified refrigerant only. Never have it mixed with any other refrigerant. Never have air remain in the refrigerant line as it may lead to rupture or other hazards.
3. Make sure no refrigerant gas is leaking out when installation is completed.
4. If there is refrigerant leakage, please take sufficient measure to minimize the density of refrigerant.
5. Never touch the refrigerant piping or compressor without wearing glove to avoid scald or frostbite.

Improper installation may lead to fire hazard, explosion, electric shock or injury.

To ensure safety, please be mindful of the following precautions.

●When installing or relocating the unit, be sure to keep the refrigerant circuit free from air or substances other than the specified refrigerant.

Any presence of air or other foreign substance in the refrigerant circuit will cause system pressure rise or compressor rupture, resulting in injury.

●When installing or moving this unit, do not charge the refrigerant which is not comply with that on the nameplate or unqualified refrigerant. Otherwise, it may cause abnormal operation, wrong action, mechanical malfunction or even series safety accident.

●When refrigerant needs to be recovered during relocating or repairing the unit, be sure that the unit is running in cooling mode. Then, fully close the valve at high pressure side (liquid valve). About 30-40 seconds later, fully close the valve at low pressure side (gas valve), immediately stop the unit and disconnect power. Please note that the time for refrigerant recovery should not exceed 1 minute.

If refrigerant recovery takes too much time, air may be sucked in and cause pressure rise or compressor rupture, resulting in injury.

●During refrigerant recovery, make sure that liquid valve and gas valve are fully closed and power is disconnected before detaching the connection pipe.

If compressor starts running when stop valve is open and connection pipe is not yet connected, air will be sucked in and cause pressure rise or compressor rupture, resulting in injury.

●When installing the unit, make sure that connection pipe is securely connected before the compressor starts running.

If compressor starts running when stop valve is open and connection pipe is not yet connected, air will be sucked in and cause pressure rise or compressor rupture, resulting in injury.

●Prohibit installing the unit at the place where there may be leaked corrosive gas or flammable gas.

If there leaked gas around the unit, it may cause explosion and other accidents.

●Do not use extension cords for electrical connections. If the electric wire is not long enough, please contact a local service center authorized and ask for a proper electric wire.

Poor connections may lead to electric shock or fire.

●Use the specified types of wires for electrical connections between the indoor and outdoor units. Firmly clamp the wires so that their terminals receive no external stresses.

Electric wires with insufficient capacity, wrong wire connections and insecure wire terminals may cause electric shock or fire.

Main Tools for Installation and Maintenance

<p>1. Level meter, measuring tape</p> 	<p>2. Screw driver</p> 	<p>3. Impact drill, drill head, electric drill</p> 
<p>4. Electroprobe</p> 	<p>5. Universal meter</p> 	<p>6. Torque wrench, open-end wrench, inner hexagon spanner</p> 
<p>7. Electronic leakage detector</p> 	<p>8. Vacuum pump</p> 	<p>9. Pressure meter</p> 
<p>10. Pipe pliers, pipe cutter</p> 	<p>11. Pipe expander, pipe bender</p> 	<p>12. Soldering appliance, refrigerant container</p> 

8. Installation

8.1 Installation Dimension Diagram

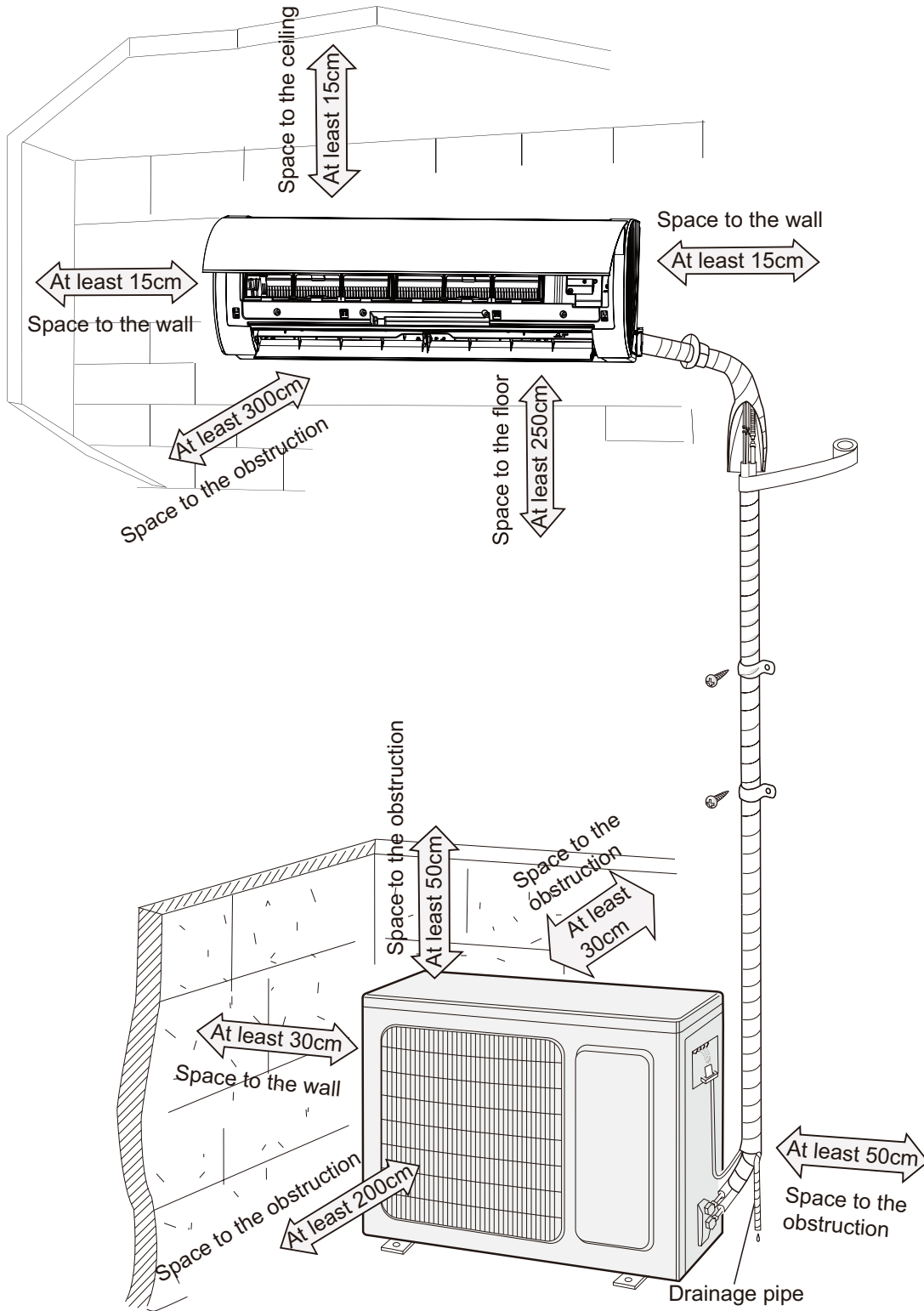

Installation procedures

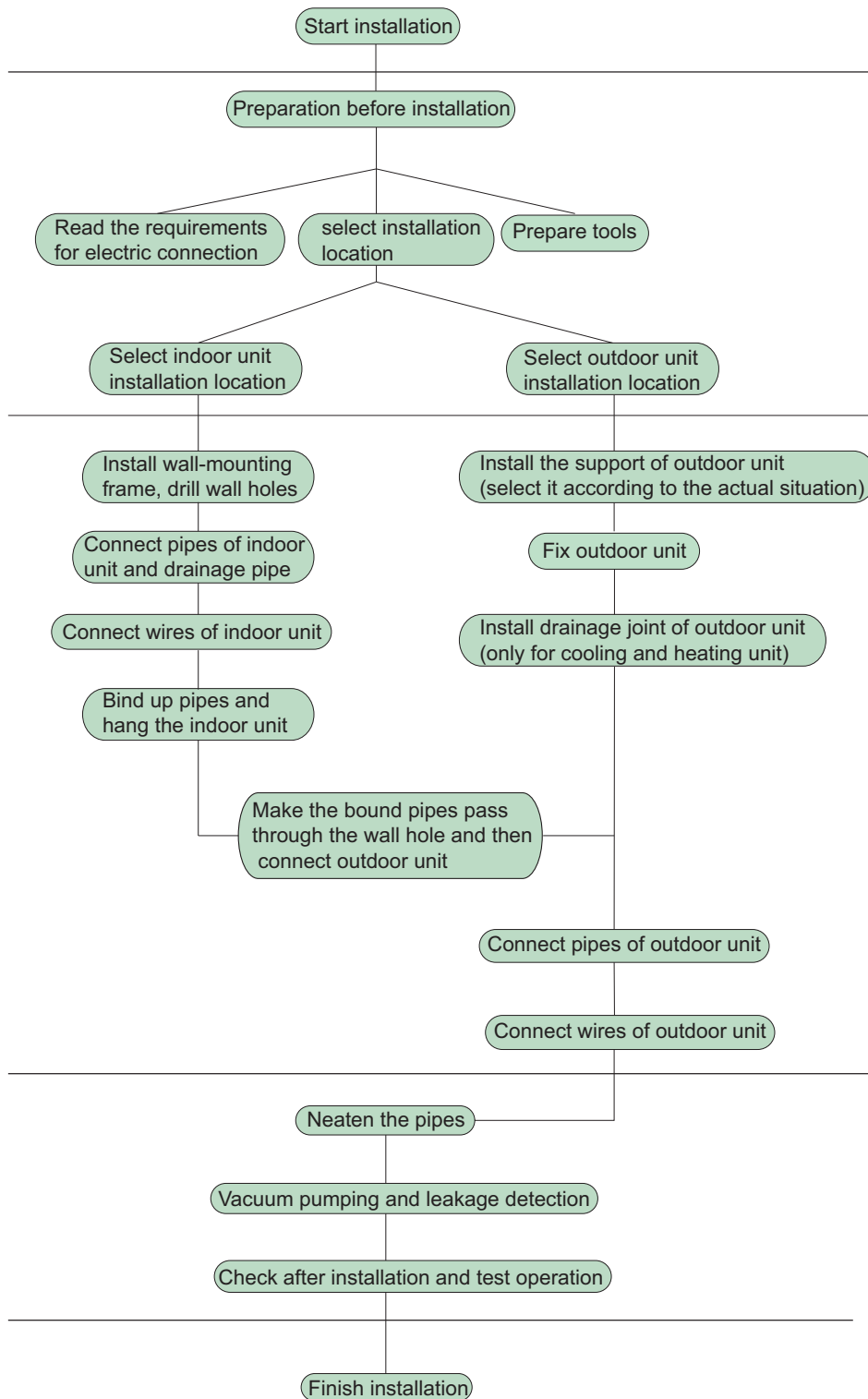

Note: this flow is only for reference; please find the more detailed installation steps in this section.

8.2 Installation Parts-Checking

No.	Name	No.	Name
1	Indoor unit	8	Sealing gum
2	Outdoor unit	9	Wrapping tape
3	Connection pipe	10	Support of outdoor unit
4	Drainage pipe	11	Fixing screw
5	Wall-mounting frame	12	Drainage plug(cooling and heating unit)
6	Connecting cable(power cord)	13	Owners manual, remote controller
7	Wall pipe		

⚠ Note:

- 1.Please contact the local agent for installation.
- 2.Dont use unqualified power cord.

8.3 Selection of Installation Location

1. Basic Requirement:

Installing the unit in the following places may cause malfunction. If it is unavoidable, please consult the local dealer:

- (1) The place with strong heat sources, vapors, flammable or explosive gas, or volatile objects spread in the air.
- (2) The place with high-frequency devices (such as welding machine, medical equipment).
- (3) The place near coast area.
- (4) The place with oil or fumes in the air.
- (5) The place with sulfureted gas.
- (6) Other places with special circumstances.
- (7) The appliance shall not be installed in the laundry.

2. Indoor Unit:

- (1) There should be no obstruction near air inlet and air outlet.
- (2) Select a location where the condensation water can be dispersed easily and wont affect other people.
- (3) Select a location which is convenient to connect the outdoor unit and near the power socket.
- (4) Select a location which is out of reach for children.
- (5) The location should be able to withstand the weight of indoor unit and wont increase noise and vibration.
- (6) The appliance must be installed 2.5m above floor.
- (7) Dont install the indoor unit right above the electric appliance.
- (8) Please try your best to keep way from fluorescent lamp.

3. Outdoor Unit:

- (1) Select a location where the noise and outflow air emitted by the outdoor unit will not affect neighborhood.
- (2) The location should be well ventilated and dry, in which the outdoor unit wont be exposed directly to sunlight or strong wind.
- (3) The location should be able to withstand the weight of outdoor unit.
- (4) Make sure that the installation follows the requirement of installation dimension diagram.
- (5) Select a location which is out of reach for children and far away from animals or plants.If it is unavoidable, please add fence for safety purpose.

8.4 Requirements for electric connection

1. Safety Precaution

- (1) Must follow the electric safety regulations when installing the unit.
- (2) According to the local safety regulations, use qualified power supply circuit and air switch.
- (3) Make sure the power supply matches with the requirement of air conditioner. Unstable power supply or incorrect wiring may result in electric shock,fire hazard or malfunction. Please install proper power supply cables before using the air conditioner.
- (4) Properly connect the live wire, neutral wire and grounding wire of power socket.
- (5) Be sure to cut off the power supply before proceeding any work related to electricity and safety.
- (6) Do not put through the power before finishing installation.
- (7) For appliances with type Y attachment,the instructions shall contain the substance of thefollowing.If the supply cord is damaged,it must be replaced by the manufacturer,its service agent or similarly qualified persons in order to avoid a hazard.
- (8) The temperature of refrigerant circuit will be high, please keep the interconnection cable away from the copper tube.
- (9) The appliance shall be installed in accordance with national wiring regulations.

2. Grounding Requirement:

- (1) The air conditioner is first class electric appliance. It must be properly grounding with specialized grounding device by a professional. Please make sure it is always grounded effectively, otherwise it may cause electric shock.
- (2) The yellow-green wire in air conditioner is grounding wire, which cant be used for other purposes.
- (3) The grounding resistance should comply with national electric safety regulations.
- (4) The appliance must be positioned so that the plug is accessible.
- (5) An all-pole disconnection switch having a contact separation of at least 3mm in all poles should be connected in fixed wiring.
- (6) Including an air switch with suitable capacity, please note the following table. Air switch should be included magnet buckle and heating buckle function, it can protect the circuit-short and overload. (Caution: please do not use the fuse only for protect the circuit)

Air-conditioner	Air switch capacity
07/09K	10A
12/18K	16A
24K	25A

8.5 Installation of Indoor Unit

1. Choosing Installation location

Recommend the installation location to the client and then confirm it with the client.

2. Install Wall-mounting Frame

- (1) Hang the wall-mounting frame on the wall; adjust it in horizontal position with the level meter and then point out the screw fixing holes on the wall.
- (2) Drill the screw fixing holes on the wall with impact drill (the specification of drill head should be the same as the plastic expansion particle) and then fill the plastic expansion particles in the holes.

(3) Fix the wall-mounting frame on the wall with tapping screws (ST4.2X25TA) and then check if the frame is firmly installed by pulling the frame. If the plastic expansion particle is loose, please drill another fixing hole nearby.

3. Install Wall-mounting Frame

(1) Choose the position of piping hole according to the direction of outlet pipe. The position of piping hole should be a little lower than the wall-mounted frame. (As show in Fig.1)

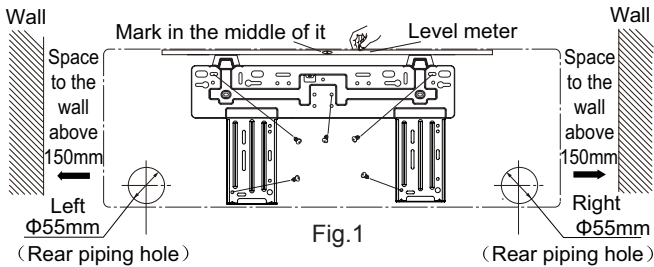

(2) Open a piping hole with the diameter of Φ55mm on the selected outlet pipe position. In order to drain smoothly, slant the piping hole on the wall slightly downward to the outdoor side with the gradient of 5-10°. (As show in Fig.2)

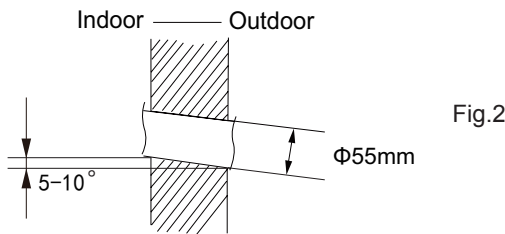

⚠ Note:

- (1) Pay attention to dust prevention and take relevant safety measures when opening the hole.
- (2) The plastic expansion particles are not provided and should be bought locally.

4. Outlet Pipe

- (1) The pipe can be led out in the direction of right, rear right, left or rear left. (As show in Fig.3)
- (2) When selecting leading out the pipe from left or right, please cut off the corresponding hole on the bottom case. (As show in Fig.4)

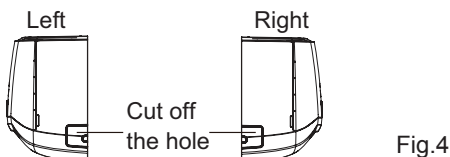
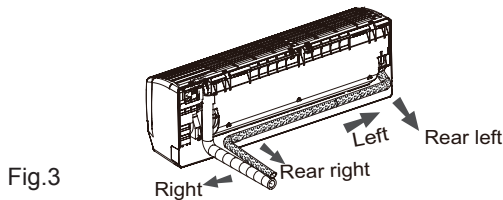

5. Connect the Pipe of Indoor Unit

- (1) Aim the pipe joint at the corresponding bellmouth. (As show in Fig.5)
- (2) Pretightening the union nut with hand.
- (3) Adjust the torque force by referring to the following sheet. Place the open-end wrench on the pipe joint and place the torque wrench on the union nut. Tighten the union nut with torque wrench. (As show in Fig.6)
- (4) Wrap the indoor pipe and joint of connection pipe with insulating pipe, and then wrap it with tape. (As show in Fig.7)

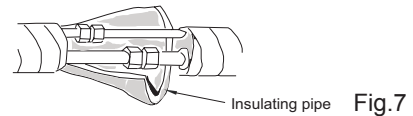
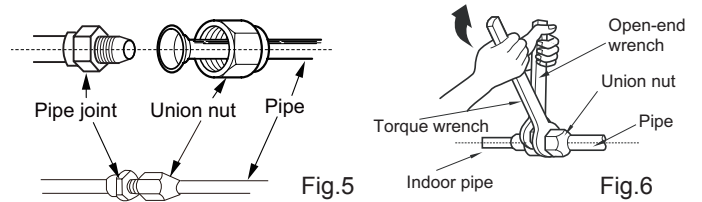

Refer to the following table for wrench moment of force:

Hex nut diameter(mm)	Tightening torque(N·m)
Φ6	15~20
Φ9.52	30~40
Φ12	45~55
Φ16	60~65
Φ19	70~75

6. Install Drain Hose

- (1) Connect the drain hose to the outlet pipe of indoor unit. (As show in Fig.8)
- (2) Bind the joint with tape. (As show in Fig.9)

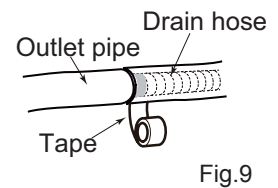
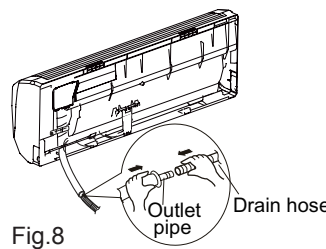

⚠ Note:

- (1) Add insulating pipe in the indoor drain hose in order to prevent condensation.
- (2) The plastic expansion particles are not provided. (As show in Fig.10)

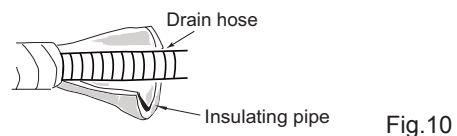

7. Connect Wire of Indoor Unit

(1) Open the panel, remove the screw on the wiring cover and then take down the cover.(As show in Fig.11)

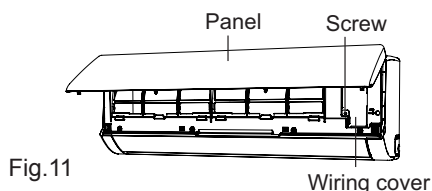

(2) Make the power connection wire go through the cable-cross hole at the back of indoor unit and then pull it out from the front side.(As show in Fig.12)

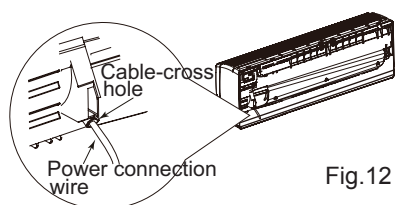

(3) Remove the wire clip; connect the power connection wiresignal control wire (only for cooling and heating unit) to the wiring terminal according to the color; tighten the screw and then fix the power connection wire with wire clip.(As show in Fig.13)

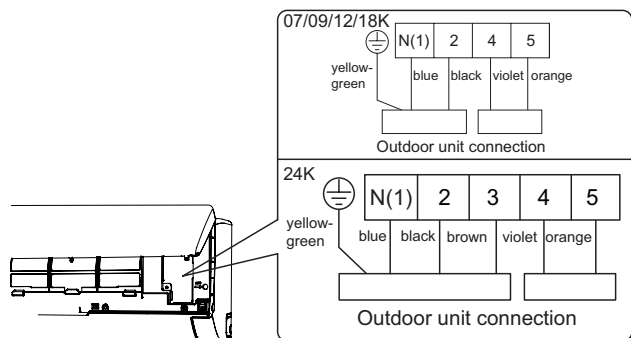

Note: The wiring connect is for reference only, please refer to the actual one.

Fig.13

(4) Put wiring cover back and then tighten the screw.
(5) Close the panel.

⚠ Note:

- (1) All wires of indoor unit and outdoor unit should be connected by a professional.
- (2) If the length of power connection wire is insufficient, please contact the supplier for a new one. Avoid extending the wire by yourself.
- (3) For the air conditioner with plug, the plug should be reachable after finishing installation.
- (4) For the air conditioner without plug, an air switch must be installed in the line. The air switch should be all-pole parting and the contact parting distance should be more than 3mm.

8. Bind up Pipe

- (1) Bind up the connection pipe, power cord and drain hose with the band.(As show in Fig.14)
- (2) Reserve a certain length of drain hose and power cord for installation when binding them. When binding to a certain degree, separate the indoor power and then separate the drain hose.(As show in Fig.15)
- (3) Bind them evenly.
- (4) The liquid pipe and gas pipe should be bound separately at the end.

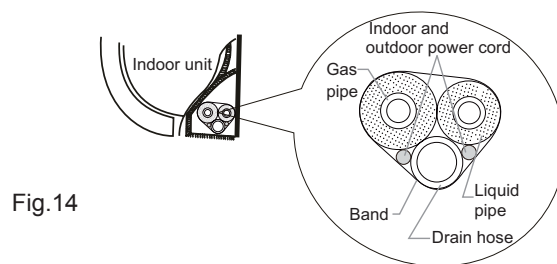

Fig.14

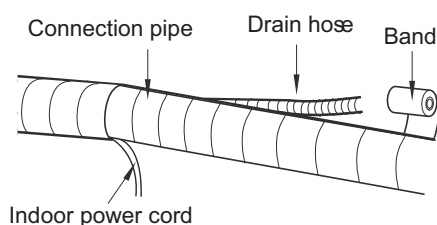

Fig.15

⚠ Note:

- (1) The power cord and control wire cant be crossed or winding.
- (2) The drain hose should be bound at the bottom.

9. Hang the Indoor Unit

- (1) Put the bound pipes in the wall pipe and then make them pass through the wall hole.
- (2) Hang the indoor unit on the wall-mounting frame.
- (3) Stuff the gap between pipes and wall hole with sealing gum.
- (4) Fix the wall pipe.(As show in Fig.16)
- (5) Check if the indoor unit is installed firmly and closed to the wall.(As show in Fig.17)

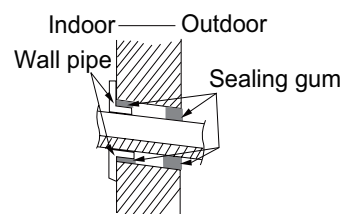

Fig.16

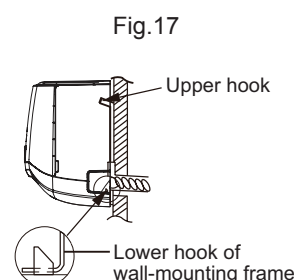

Fig.17

⚠ Note:

Do not bend the drain hose too excessively in order to prevent blocking.

8.6 Installation of Outdoor unit

1. Fix the Support of Outdoor Unit(Select it according to the actual installation situation)

- (1) Select installation location according to the house structure.
- (2) Fix the support of outdoor unit on the selected location with expansion screws.

⚠ Note:

- (1) Take sufficient protective measures when installing the outdoor unit.
- (2) Make sure the support can withstand at least four times the unit weight.
- (3) The outdoor unit should be installed at least 3cm above the floor in order to install drain joint.(As show in Fig.18)
- (4) For the unit with cooling capacity of 2300W~5000W, 6 expansion screws are needed; for the unit with cooling capacity of 6000W~8000W, 8 expansion screws are needed; for the unit with cooling capacity of 10000W~16000W, 10 expansion screws are needed.

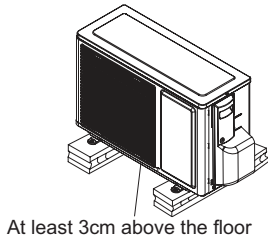

Fig.18

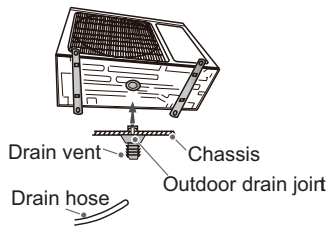

Fig.19

2. Install Drain Joint(Only for cooling and heating unit)

- (1) Connect the outdoor drain joint into the hole on the chassis.
 - (2) Connect the drain hose into the drain vent.
- (As show in Fig.19)

3. Fix Outdoor Unit

- (1) Place the outdoor unit on the support.
 - (2) Fix the foot holes of outdoor unit with bolts.
- (As show in Fig.20)

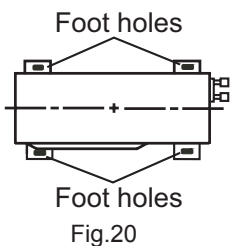

Fig.20

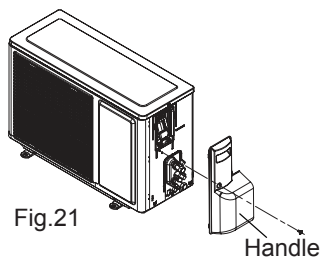

Fig.21

4. Connect Indoor and Outdoor Pipes

- (1) Remove the screw on the right handle of outdoor unit and then remove the handle.(As show in Fig.21)
- (2) Remove the screw cap of valve and aim the pipe joint at the bellmouth of pipe.(As show in Fig.22)

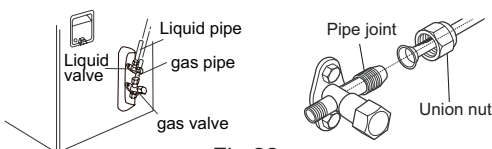

Fig.22

- (3) Pretightening the union nut with hand.
- (4) Tighten the union nut with torque wrench .

Refer to the following table for wrench moment of force:

Hex nut diameter(mm)	Tightening torque(N·m)
Φ6	15~20
Φ9.52	30~40
Φ12	45~55
Φ16	60~65
Φ19	70~75

5. Connect Outdoor Electric Wire

- (1) Remove the wire clip; connect the power connection wire and signal control wire (only for cooling and heating unit) to the wiring terminal according to the color; fix them with screws.(As show in Fig.23)

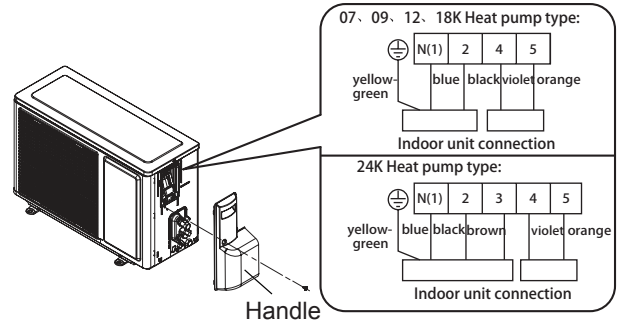

Note: the wiring connect is for reference only,please refer to the actual one.

Fig.23

- (2) Fix the power connection wire and signal control wire with wire clip (only for cooling and heating unit).

⚠ Note:

- (1) After tightening the screw, pull the power cord slightly to check if it is firm.
- (2) Never cut the power connection wire to prolong or shorten the distance.

6. Neaten the Pipes

- (1) The pipes should be placed along the wall, bent reasonably and hidden possibly. Min. semidiameter of bending the pipe is 10cm.
- (2) If the outdoor unit is higher than the wall hole, you must set a U-shaped curve in the pipe before pipe goes into the room, in order to prevent rain from getting into the room.(As show in Fig.24)

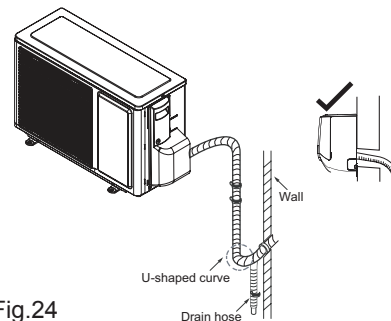

Fig.24

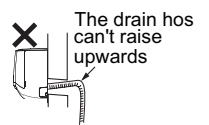

Fig.25

⚠ Note:

- (1) The through-wall height of drain hose shouldnt be higher than the outlet pipe hole of indoor unit.(As show in Fig.25)
- (2) Slant the drain hose slightly downwards. The drain hose cant be curved, raised and fluctuant, etc.(As show in Fig.26)

(3) The water outlet can't be placed in water in order to drain smoothly.(As show in Fig.27)

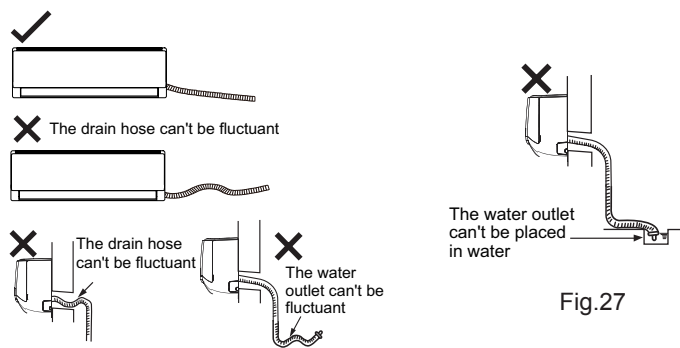

Fig.26

Fig.27

8.7 Vacuum Pumping and Leak Detection

1. Use Vacuum Pump

- (1) Remove the valve caps on the liquid valve and gas valve and the nut of refrigerant charging vent.
- (2) Connect the charging hose of piezometer to the refrigerant charging vent of gas valve and then connect the other charging hose to the vacuum pump.
- (3) Open the piezometer completely and operate for 10-15min to check if the pressure of piezometer remains in -0.1MPa .
- (4) Close the vacuum pump and maintain this status for 1-2min to check if the pressure of piezometer remains in -0.1MPa . If the pressure decreases, there may be leakage.
- (5) Remove the piezometer, open the valve core of liquid valve and gas valve completely with inner hexagon spanner.
- (6) Tighten the screw caps of valves and refrigerant charging vent.(As show in Fig.28)

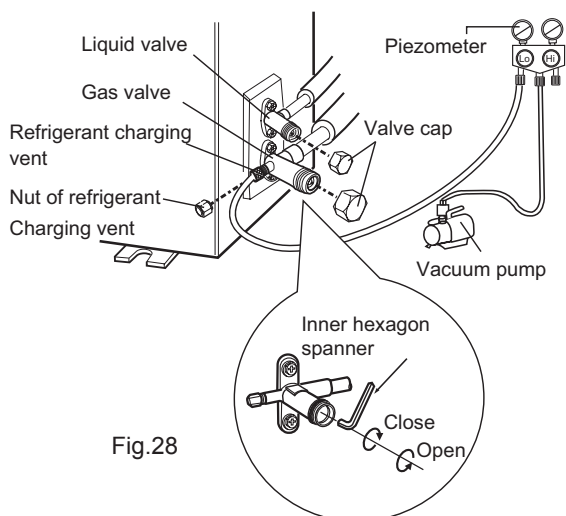

Fig.28

2. Leakage Detection

- (1) With leakage detector:
Check if there is leakage with leakage detector.
- (2) With soap water:
If leakage detector is not available, please use soap water for leakage detection. Apply soap water at the suspected position and keep the soap water for more than 3min. If there are air bubbles coming out of this position, there's a leakage.

8.8 Check after Installation and Test operation

1. Check after Installation

Check according to the following requirement after finishing installation.

NO.	Items to be checked	Possible malfunction
1	Has the unit been installed firmly?	The unit may drop, shake or emit noise.
2	Have you done the refrigerant leakage test?	It may cause insufficient cooling (heating) capacity.
3	Is heat insulation of pipeline sufficient?	It may cause condensation and water dripping.
4	Is water drained well?	It may cause condensation and water dripping.
5	Is the voltage of power supply according to the voltage marked on the nameplate?	It may cause malfunction or damage the parts.
6	Is electric wiring and pipeline installed correctly?	It may cause malfunction or damage the parts.
7	Is the unit grounded securely?	It may cause electric leakage.
8	Does the power cord follow the specification?	It may cause malfunction or damage the parts.
9	Is there any obstruction in air inlet and air outlet?	It may cause insufficient cooling (heating) capacity.
10	The dust and sundries caused during installation are removed?	It may cause malfunction or damaging the parts.
11	The gas valve and liquid valve of connection pipe are open completely?	It may cause insufficient cooling (heating) capacity.
12	Is the inlet and outlet of piping hole been covered?	It may cause insufficient cooling (heating) capacity or waster eletricity.

2. Test Operation

- (1) Preparation of test operation
 - The client approves the air conditioner installation.
 - Specify the important notes for air conditioner to the client.
- (2) Method of test operation
 - Put through the power, press ON/OFF button on the remote controller to start operation.
 - Press MODE button to select AUTO, COOL, DRY, FAN and HEAT to check whether the operation is normal or not.
 - If the ambient temperature is lower than 16°C , the air conditioner can't start cooling.

9. Maintenance

9.1 Error code

No.	Malfunction Name	Display Method of Indoor Unit (Error Code)	A/C Status	Possible Causes(For specific maintenance method, please refer to the following procedure of troubleshooting)
1	Indoor ambient temperature sensor is open/short-circuited	F1	The unit will stop operation as it reaches the temperature point. During cooling and drying operation, except IDU fan motor operates, other loads stop operation; During heating operation, the system stops operation.	<ol style="list-style-type: none"> 1.The wiring terminal between indoor ambient temperature sensor and main board is loosened or poorly contacted; 2. There's short circuit due to trip-over of the parts on controller; 3. Indoor ambient temperature sensor is damaged (Please check it by referring to the resistance table for temperature sensor) 4. Main board is broken.
2	Indoor evaporator temperature sensor is open/short-circuited	F2	The unit will stop operation as it reaches the temperature point. During cooling and drying operation, except IDU fan operates, other loads stop operation; During heating operation, the complete unit stops operation.	<ol style="list-style-type: none"> 1.The wiring terminal between indoor evaporator temperature sensor and main board is loosened or poorly contacted; 2. There's short circuit due to the trip-over of the parts on controller; 3. Indoor evaporator temperature sensor is damaged (Please check it by referring to the resistance table for temperature sensor) 4. Main board is broken.
3	Blocked protection of IDU fan motor	H6	IDU fan, ODU fan, compressor and electric heat tube stop operation. Horizontal louver stops at the current position.	<ol style="list-style-type: none"> 1.The feedback terminal of PG motor is not connected tightly. 2.The control terminal of PG motor is not connected tightly. 3.Fan blade rotates unsmoothly. 4.Malfunction of motor 5.Main board is broken.
4	Malfunction protection of jumper cap	C5	Operation of remote controller or control panel is available, but the unit won't act.	<ol style="list-style-type: none"> 1. There's not jumper cap on the main board. 2. Jumper cap is not inserted properly and tightly. 3. Jumper cap is damaged. 4. Controller is damaged.
5	Overload malfunction	E8	The entire unit stops.	<ol style="list-style-type: none"> 1. Indoor and outdoor heat exchanger is too dirty? Or air inlet/outlet is blocked? 2. Fan motor is not working. Abnormal fan speed; fan speed is too low or the fan doesn't run. 3. Compressor operates normally or not? Is there any abnormal noise or oil leak? Casing is too hot? 4. System is blocked inside? (Dirt blockage? Ice blockage? Oil blockage? Y-valve is not fully open?) 5. Main board temperature sensor detects wrongly.
6	Zero-crossing inspection circuit malfunction of the IDU fan motor	U8	Operation of remote controller or control panel is available, but the unit won't act.	<ol style="list-style-type: none"> 1. Quick de-energization and energization. Wrong judgement by the controller because the electric-discharging of capacitor is slow. 2. Zero-crossing inspection circuit of main board for controller is abnormal.

7	Lack of refrigerant or block protection for the system	F0	The Dual-8 Code Display will show F0 and the complete unit stops.	<ol style="list-style-type: none"> 1.Refrigerant leakage; 2.Indoor evaporator temperature sensor works abnormally; 3.The unit has been plugged up somewhere; 4.The compressor can't be started up normally. Because the power voltage for the complete unit is too low, and the outdoor working condition is too high.
8	High pressure protection	E1	During cooling and drying operation, except indoor fan operates, all loads stop operation. During heating operation, if it is inverter unit, the complete unit stops; if it is floor standing unit, the complete unit stops and operation of remote controller or controller is unavailable.	<ol style="list-style-type: none"> 1. The main board and the display panel are not connected well. 2. The OVC terminal on main board is not connected well with the high pressure switch on the complete unit. 3. The wiring of high pressure switch is loosened. 4. Refrigerant is superabundant; 5. Poor heat exchange (including blocked heat exchanger and bad radiating environment); 6. Ambient temperature is too high; (if it is 3-phase unit, the high pressure protection may be caused by overcurrent protection due to this reason) 7. The supply voltage is abnormal (if it is 3-phase unit, the high pressure protection may be caused by overcurrent protection due to this reason) 8. The air intake and air discharge at indoor / outdoor heat exchanger are not smooth. The air cycle is short circuited. 9. Filter and heat exchange fins of indoor/outdoor units are blocked. 10. The system pipeline is blocked. 11. The gas valve and liquid valve for outdoor unit are not completely opened. 12. The OVC input is at high level.
9	Overcurrent protection(This protection function is not available for those models whose cooling capacity ≤12000Btu/h)	E5	During cooling and drying operation, except IDU fan motor operates, other loads stop operation; During heating operation, the system stops operation.	<ol style="list-style-type: none"> 1. Unstable supply voltage. Normal fluctuation shall be within 10% of the rated voltage on the nameplate. 2. Supply voltage is too low and load is too high. 3. Measure the current of live wire on main board. If the current isnt higher than the overcurrent protection value, please check the controller. 4. The indoor and outdoor heat exchangers are too dirty, or the air inlet and air outlet are blocked. 5. The fan motor is not running. Abnormal fan speed: fan speed is too low or the fan doesnt run 6. The compressor is not running normally. There is abnormal sound, oil leakage or the temperature of the shell is too high, etc. 7. Theres blockage in the system (filth blockage, ice plug, greasy blockage, Y-valve hasnt been opened completely)
10	Overload protection for compressor	H3	The entire unit stops.	<ol style="list-style-type: none"> 1. Outdoor and indoor heat exchangers are too dirty or the air inlet/outlet is blocked. 2. Fan motor is not working Abnormal fan speed; fan speed is too low or the fan doesnt run. 3. Compressor doesnt work normally. Strange noise or leakage occurs. Temperature of the shell is too high. 4. System is blocked inside(dirt block, ice block, oil block, Y-valve not fully open). 5. High pressure switch is abnormal 6. The refrigerant is leaking and cause overheating protection to compressor

9.2 Procedure of Troubleshooting

1. Malfunction of Temperature Sensor F1, F2

Main detection points:

- Is the wiring terminal between the temperature sensor and the controller loosened or poorly contacted?
- Is there short circuit due to trip-over of the parts?
- Is the temperature sensor broken?
- Is mainboard broken?

Malfunction diagnosis process:

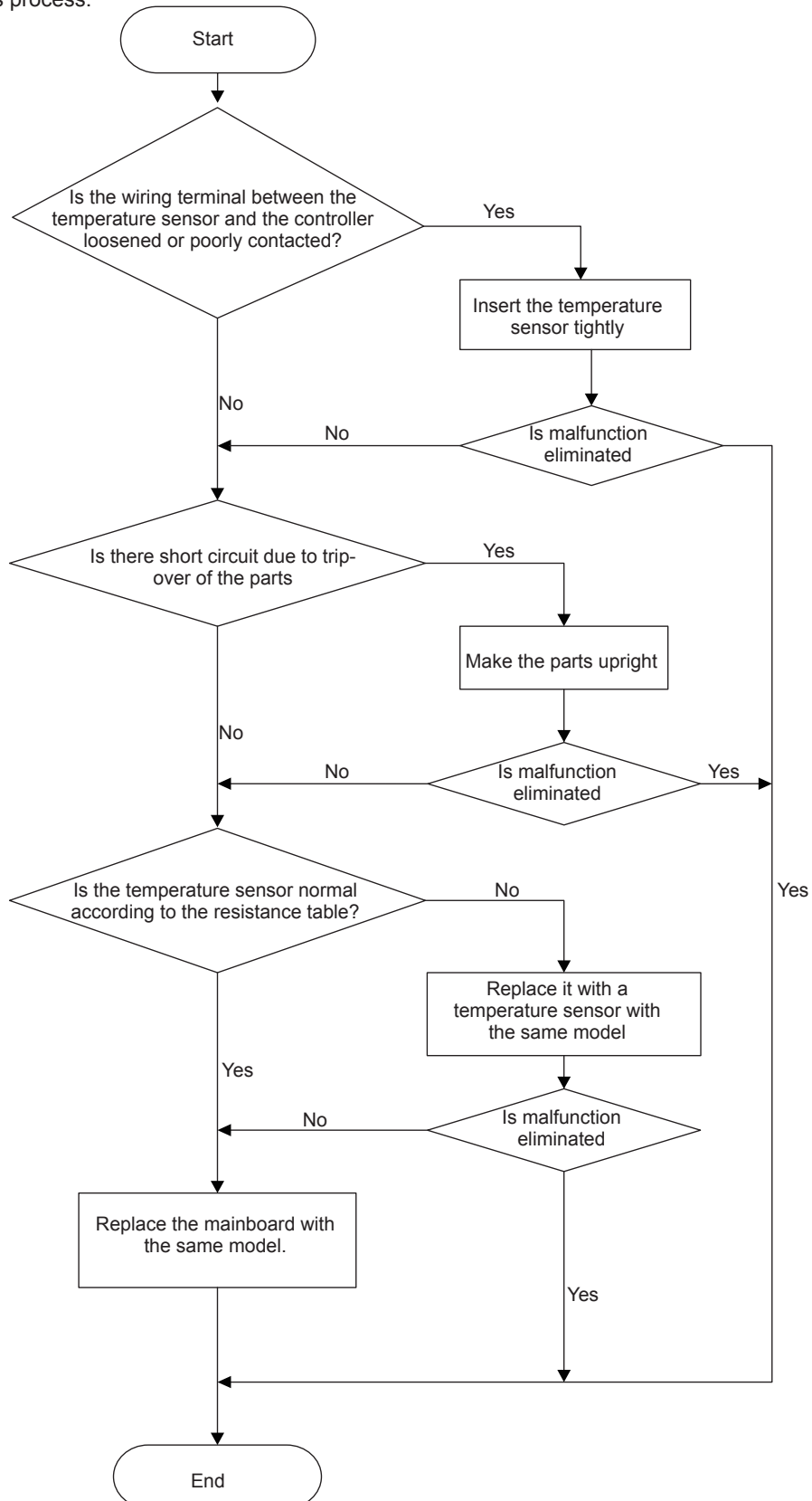

2. Malfunction of Blocked Protection of IDU Fan Motor H6

Main detection points:

- Smoothly Is the control terminal of PG motor connected tightly?
- Smoothly Is the feedback interface of PG motor connected tightly?
- The fan motor can't operate?
- The motor is broken?
- Detection circuit of the mainboard is defined abnormal?

Malfunction diagnosis process:

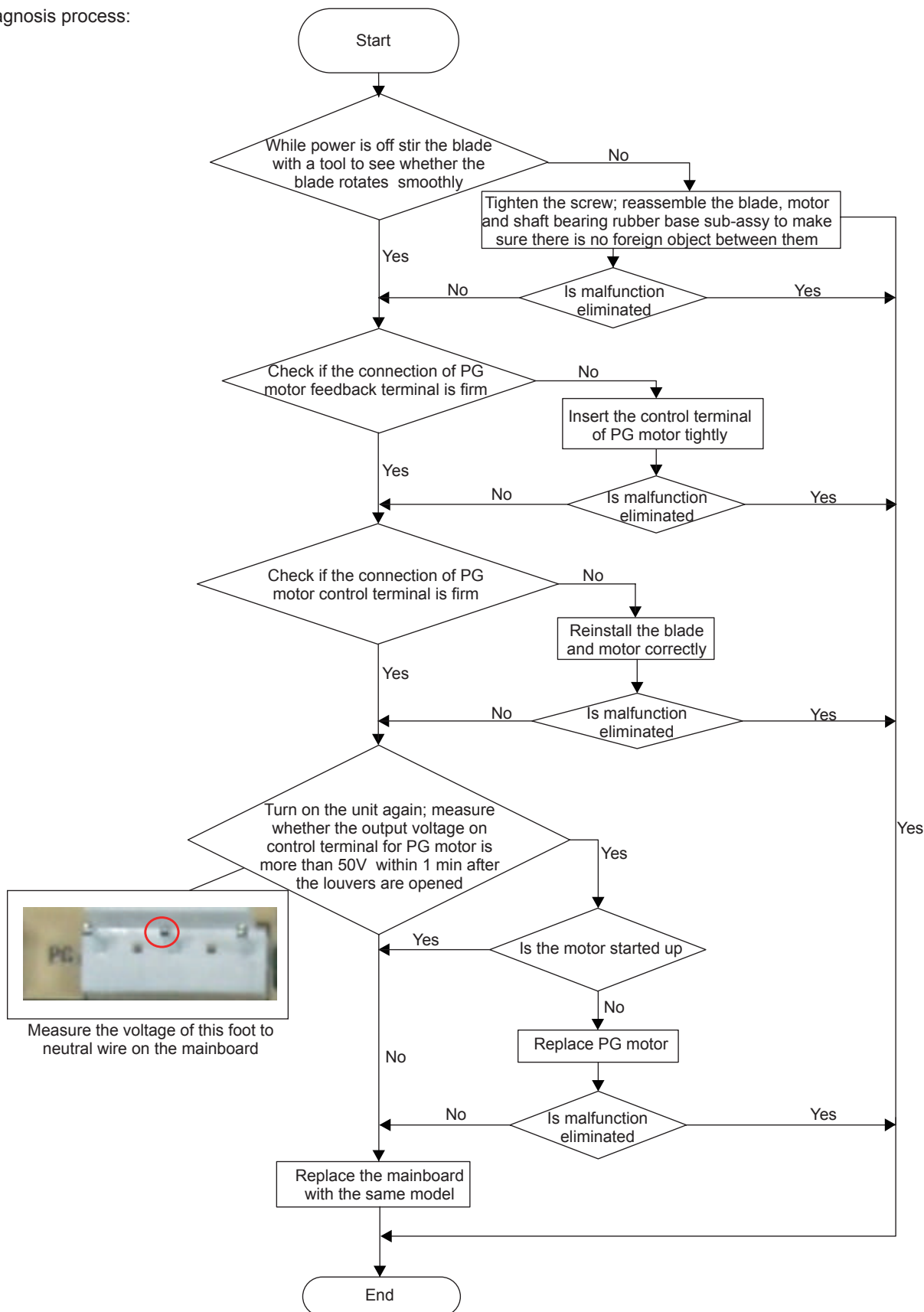

3. Malfunction of Protection of Jumper Cap C5

Main detection points:

- Is there jumper cap on the mainboard?
- Is the jumper cap inserted correctly and tightly?
- The jumper is broken?
- The motor is broken?
- Detection circuit of the mainboard is defined abnormal?

Malfunction diagnosis process:

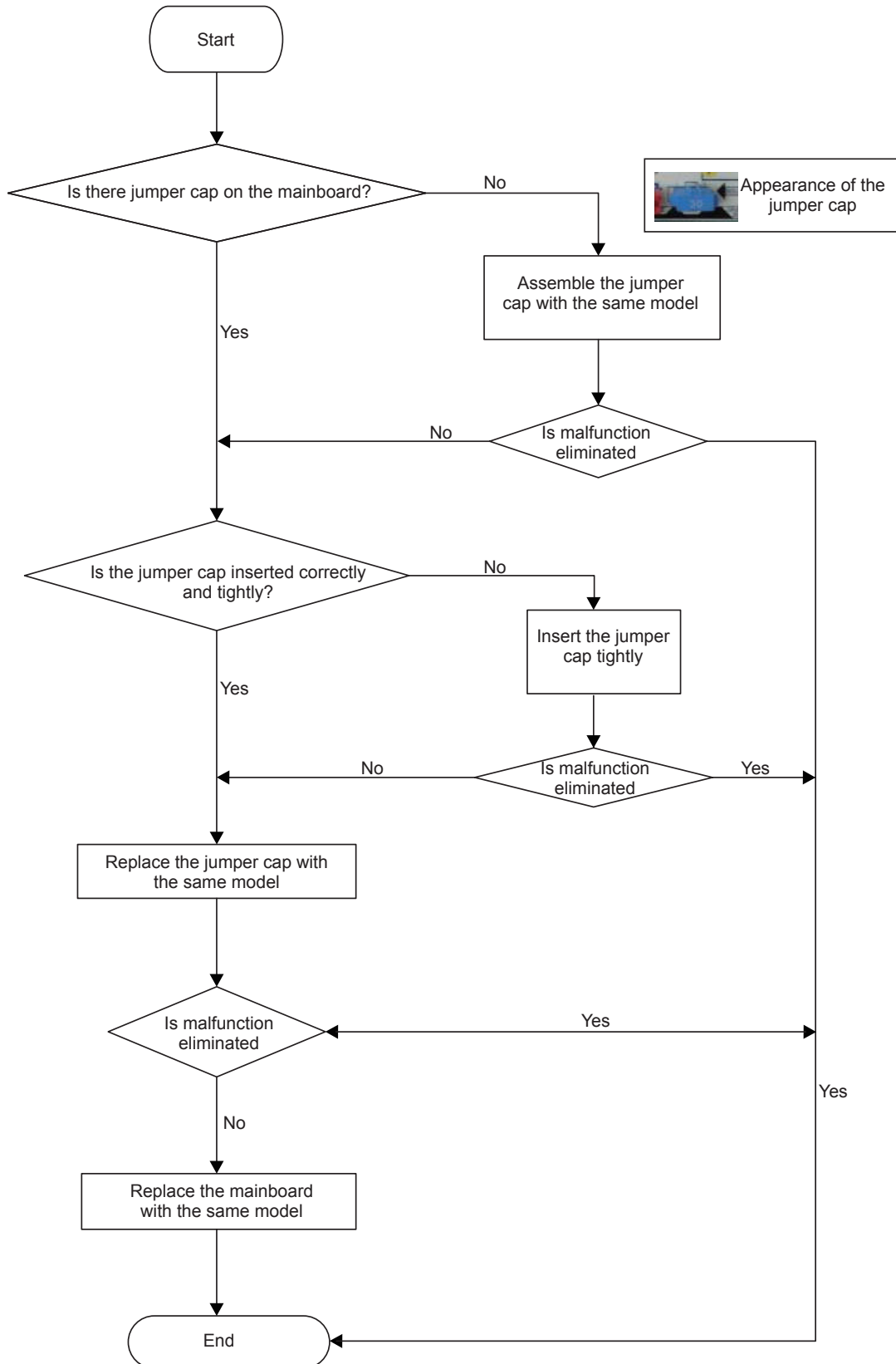

4. Malfunction of Zero-crossing Inspection Circuit Malfunction of the IDU Fan Motor U8

Main detection points:

- Instant energization after de-energization while the capacitor discharges slowly?
- The zero-cross detection circuit of the mainboard is defined abnormal?

Malfunction diagnosis process:

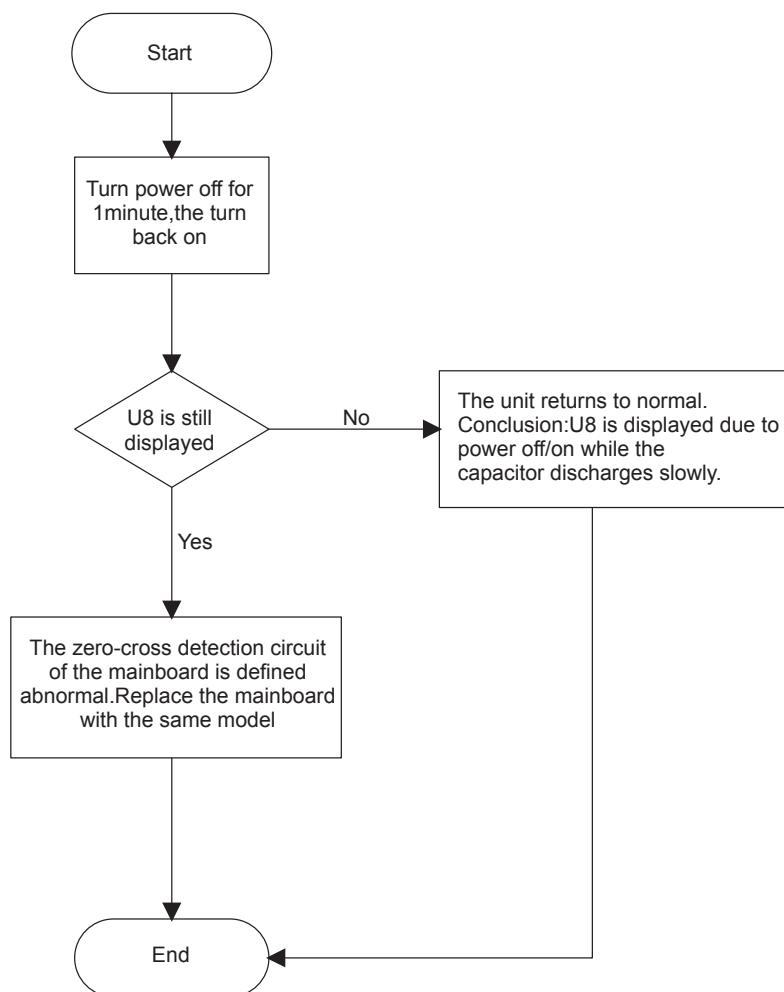

5. High Temperature and Overload Protection (AP1 below means control board of outdoor unit) E8

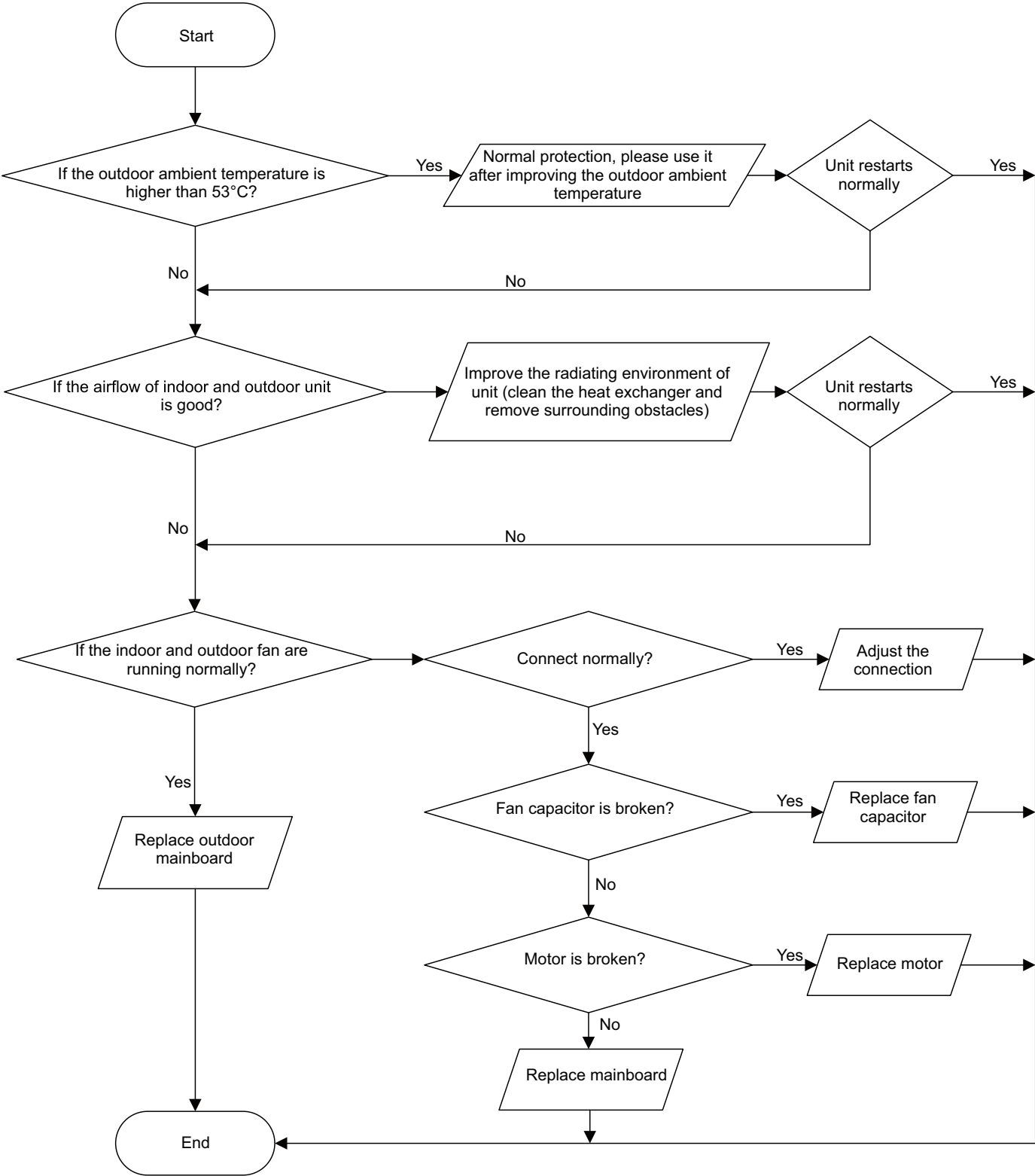

6. Malfunction of Insufficient fluorine protection F0

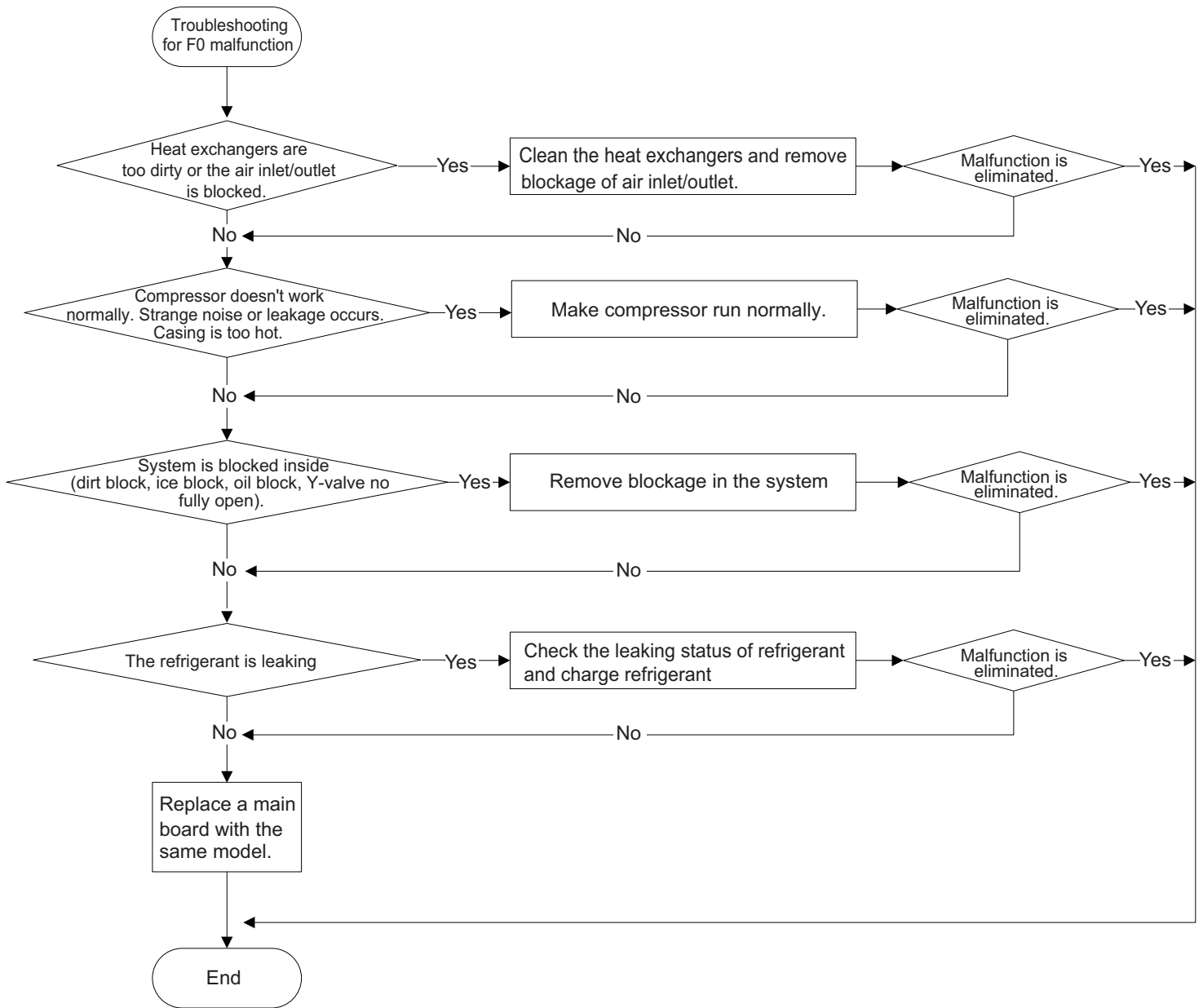

7. Malfunction of Overcurrent Protection E5

Main detection points:

- Is the supply voltage unstable with big fluctuation?
- Is the supply voltage too low with overload?
- Hardware trouble?

Malfunction diagnosis process:

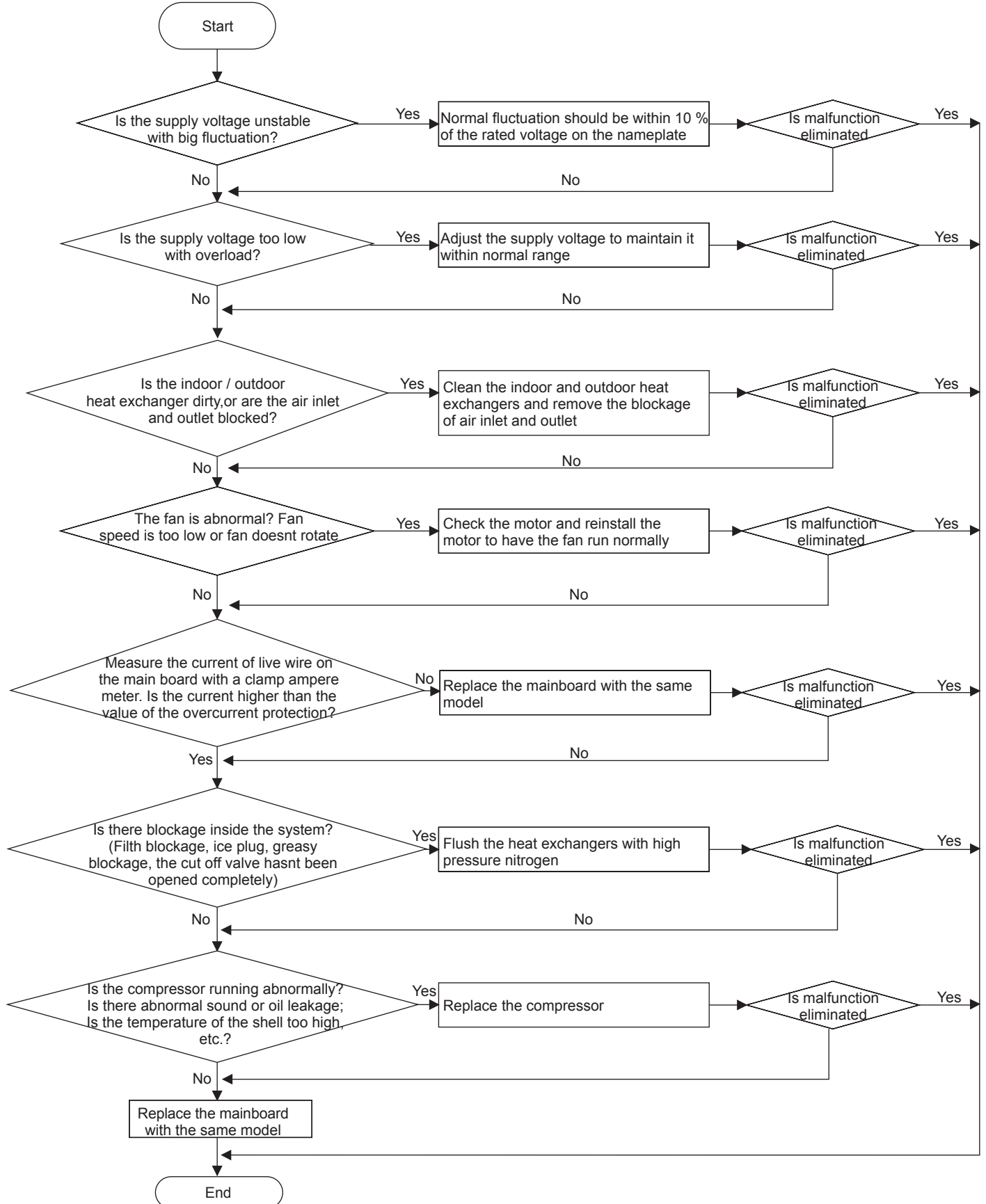

8. High pressure protection (E1)

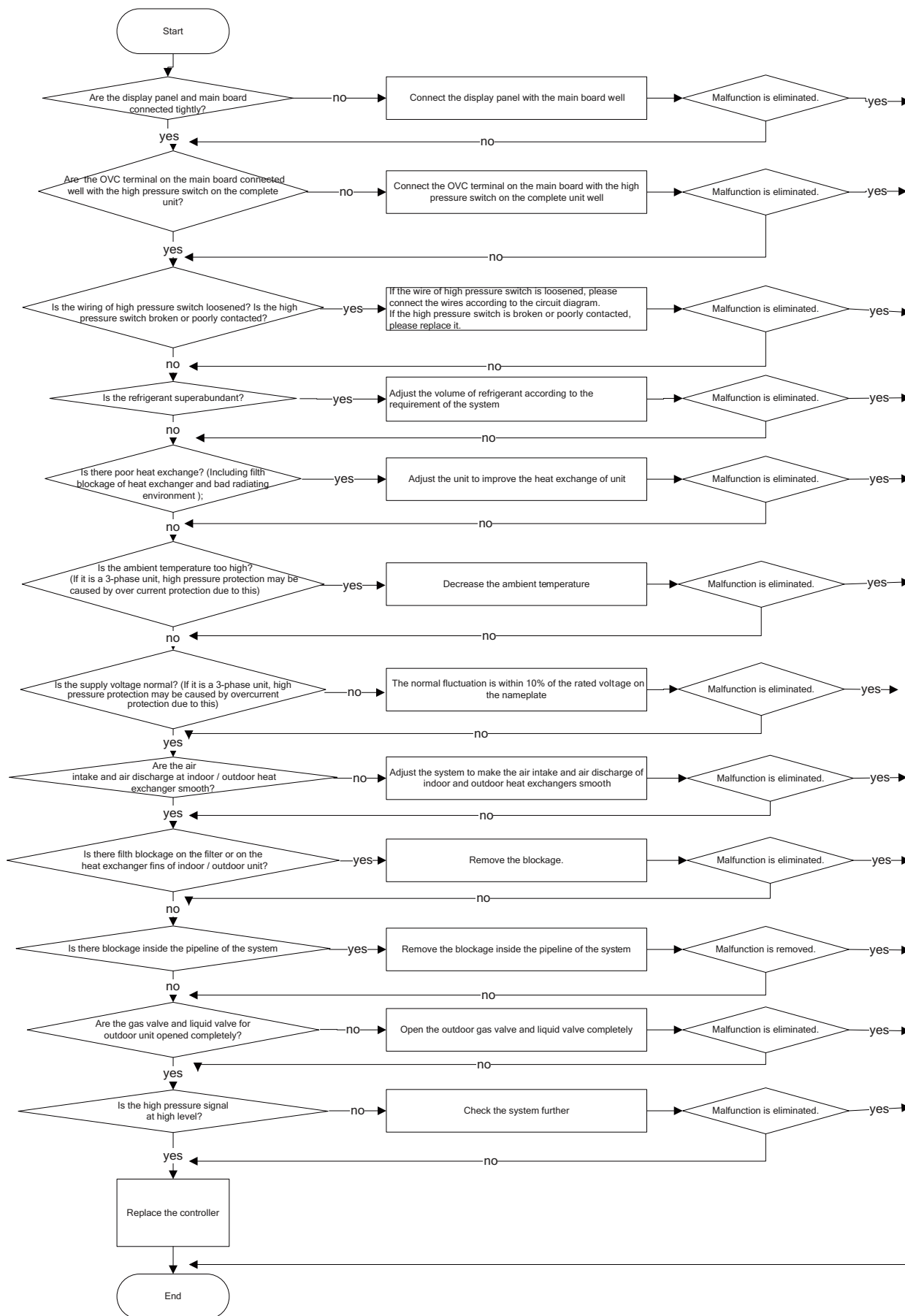

9. Overload Protection Compressor H3

Main detection points:

- Heat exchange of unit is not good? (heat exchanger is dirty and unit radiating environment is bad)
- Fan motor is not working?
- Too much load of the system causes high temperature of compressor after working for a long time?
- Whether high pressure switch is normal?
- If the refrigerant is leaked?

Malfunction diagnosis process:

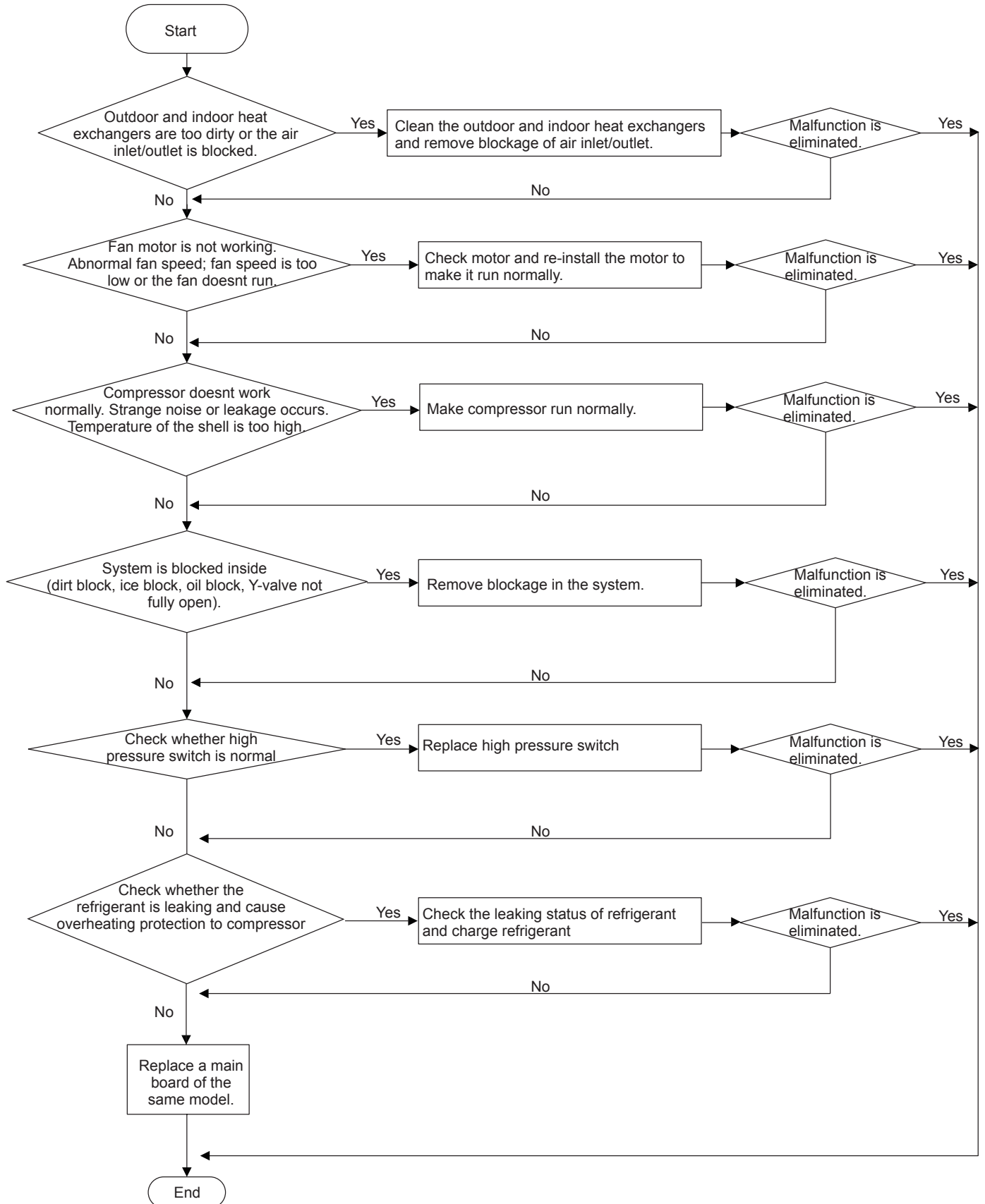

9.3 Maintenance method for normal malfunction

1. Air Conditioner Cant be Started Up

Possible Causes	Discriminating Method (Air conditioner Status)	Troubleshooting
No power supply, or poor connection for power plug	After energization, operation indicator isnt bright and the buzzer cant give out sound	Confirm whether its due to power failure. If yes, wait for power recovery. If not, check power supply circuit and make sure the power plug is connected well.
Wrong wire connection between indoor unit and outdoor unit, or poor connection for wiring terminals	Under normal power supply circumstances, operation indicator isnt bright after energization	Check the circuit according to circuit diagram and connect wires correctly. Make sure all wiring terminals are connected firmly
Electric leakage for air conditioner	After energization, room circuit breaker trips off at once	Make sure the air conditioner is grounded reliably Make sure wires of air conditioner is connected correctly Check the wiring inside air conditioner. Check whether the insulation layer of power cord is damaged; if yes, place the power cord.
Model selection for air switch is improper	After energization, air switch trips off	Select proper air switch
Malfunction of remote controller	After energization, operation indicator is bright, while no display on remote controller or buttons have no action.	Replace batteries for remote controller Repair or replace remote controller

2. Poor Cooling (Heating) for Air Conditioner

Possible Causes	Discriminating Method (Air conditioner Status)	Troubleshooting
Set temperature is improper	Observe the set temperature on remote controller	Adjust the set temperature
Rotation speed of the IDU fan motor is set too low	Small wind blow	Set the fan speed at high or medium
Filter of indoor unit is blocked	Check the filter to see its blocked	Clean the filter
Installation position for indoor unit and outdoor unit is improper	Check whether the installation position is proper according to installation requirement for air conditioner	Adjust the installation position, and install the rainproof and sunproof for outdoor unit
Refrigerant is leaking	Discharged air temperature during cooling is higher than normal discharged wind temperature; Discharged air temperature during heating is lower than normal discharged wind temperature; Units pressure is much lower than regulated range	Find out the leakage causes and deal with it. Add refrigerant.
Malfunction of 4-way valve	Blow cold wind during heating	Replace the 4-way valve
Malfunction of capillary	Discharged air temperature during cooling is higher than normal discharged wind temperature; Discharged air temperature during heating is lower than normal discharged wind temperature; Unit pressure is much lower than regulated range. If refrigerant isnt leaking, part of capillary is blocked	Replace the capillary
Flow volume of valve is insufficient	The pressure of valves is much lower than that stated in the specification	Open the valve completely
Malfunction of horizontal louver	Horizontal louver cant swing	Refer to point 3 of maintenance method for details
Malfunction of the IDU fan motor	The IDU fan motor cant operate	Refer to troubleshooting for H6 for maintenance method in details
Malfunction of the ODU fan motor	The ODU fan motor cant operate	Refer to point 4 of maintenance method for details
Malfunction of compressor	Compressor cant operate	Refer to point 5 of maintenance method for details

3. Horizontal Louver Cant Swing

Possible Causes	Discriminating Method (Air conditioner Status)	Troubleshooting
Wrong wire connection, or poor connection	Check the wiring status according to circuit diagram	Connect wires according to wiring diagram to make sure all wiring terminals are connected firmly
Stepping motor is damaged	Stepping motor cant operate	Repair or replace stepping motor
Main board is damaged	Others are all normal, while horizontal louver cant operate	Replace the main board with the same model

4. ODU Fan Motor Cant Operate

Possible causes	Discriminating method (air conditioner status)	Troubleshooting
Wrong wire connection, or poor connection	Check the wiring status according to circuit diagram	Connect wires according to wiring diagram to make sure all wiring terminals are connected firmly
Capacity of the ODU fan motor is damaged	Measure the capacity of fan capacitor with an universal meter and find that the capacity is out of the deviation range indicated on the nameplate of fan capacitor.	Replace the capacity of fan
Power voltage is a little low or high	Use universal meter to measure the power supply voltage. The voltage is a little high or low	Suggest to equip with voltage regulator
Motor of outdoor unit is damaged	When unit is on, cooling/heating performance is bad and ODU compressor generates a lot of noise and heat.	Change compressor oil and refrigerant. If no better, replace the compressor with a new one

5. Compressor Cant Operate

Possible causes	Discriminating method (air conditioner status)	Troubleshooting
Wrong wire connection, or poor connection	Check the wiring status according to circuit diagram	Connect wires according to wiring diagram to make sure all wiring terminals are connected firmly
Capacity of compressor is damaged	Measure the capacity of fan capacitor with an universal meter and find that the capacity is out of the deviation range indicated on the nameplate of fan capacitor.	Replace the compressor capacitor
Power voltage is a little low or high	Use universal meter to measure the power supply voltage. The voltage is a little high or low	Suggest to equip with voltage regulator
Coil of compressor is burnt out	Use universal meter to measure the resistance between compressor terminals and its 0	Repair or replace compressor
Cylinder of compressor is blocked	Compressor cant operate	Repair or replace compressor

6. Air Conditioner is Leaking

Possible causes	Discriminating method (air conditioner status)	Troubleshooting
Drain pipe is blocked	Water leaking from indoor unit	Eliminate the foreign objects inside the drain pipe
Drain pipe is broken	Water leaking from drain pipe	Replace drain pipe
Wrapping is not tight	Water leaking from the pipe connection place of indoor unit	Wrap it again and bundle it tightly

7. Abnormal Sound and Vibration

Possible causes	Discriminating method (air conditioner status)	Troubleshooting
When turn on or turn off the unit, the panel and other parts will expand and theres abnormal sound	Theres the sound of "PAPA"	Normal phenomenon. Abnormal sound will disappear after a few minutes.
When turn on or turn off the unit, theres abnormal sound due to flow of refrigerant inside air conditioner	Water-running sound can be heard	Normal phenomenon. Abnormal sound will disappear after a few minutes.
Foreign objects inside the indoor unit or therere parts touching together inside the indoor unit	Theres abnormal sound fro indoor unit	Remove foreign objects. Adjust all parts position of indoor unit, tighten screws and stick damping plaster between connected parts
Foreign objects inside the outdoor unit or therere parts touching together inside the outdoor unit	Theres abnormal sound fro outdoor unit	Remove foreign objects. Adjust all parts position of outdoor unit, tighten screws and stick damping plaster between connected parts
Short circuit inside the magnetic coil	During heating, the way valve has abnormal electromagnetic sound	Replace magnetic coil
Abnormal shake of compressor	Outdoor unit gives out abnormal sound	Adjust the support foot mat of compressor, tighten the bolts
Abnormal sound inside the compressor	Abnormal sound inside the compressor	If add too much refrigerant during maintenance, please reduce refrigerant properly. Replace compressor for other circumstances.

10. Exploded View and Parts List

10.1 Indoor Unit

GWH07AFA-K3NNA1A/I

GWH09AFB-K3NNA1A/I GWH12AFB-K3NNA1A/I

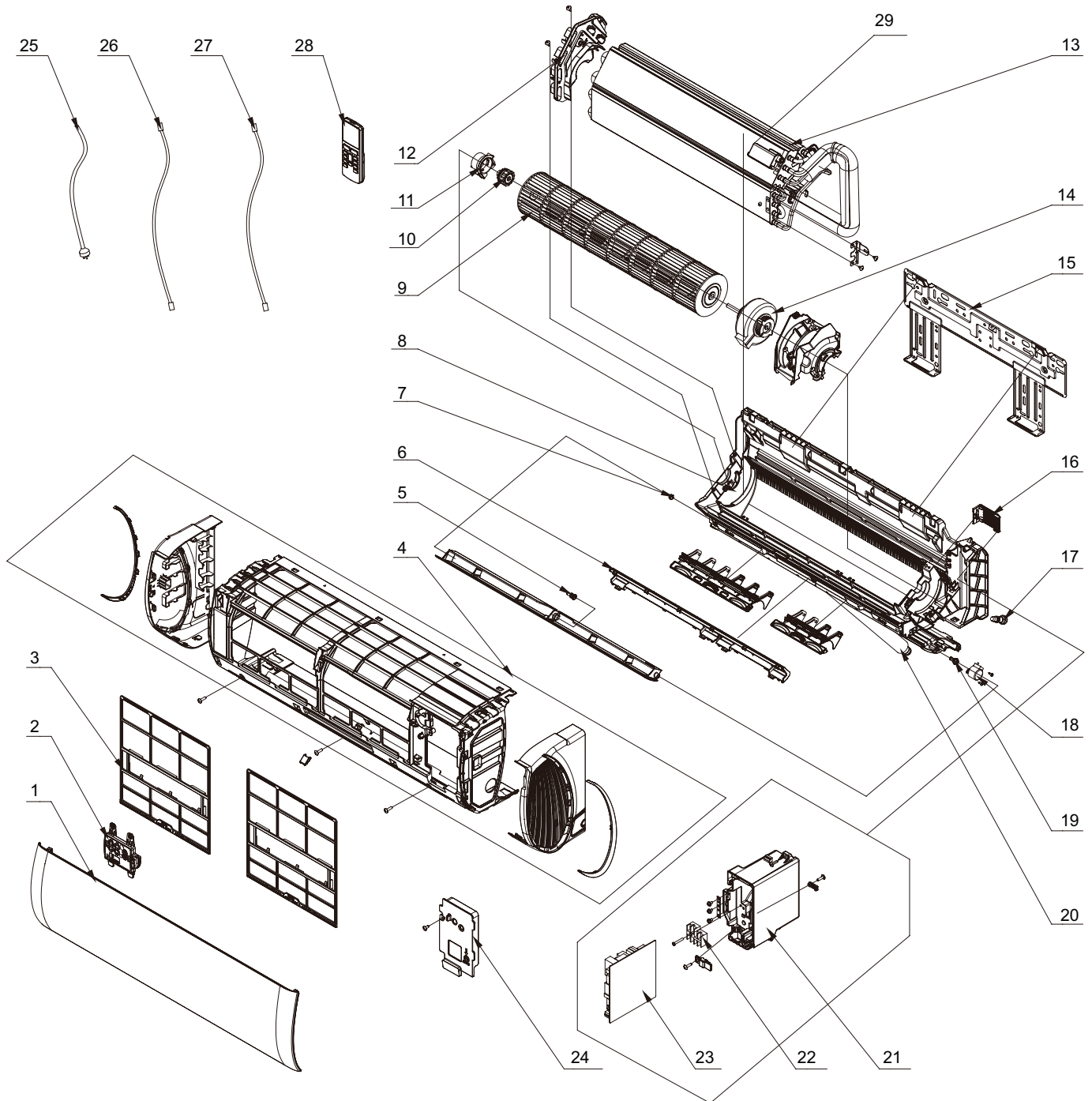

The component picture is only for reference; please refer to the actual product.

NO.	Description	Part Code			Qty
		GWH07AFA-K3NNA1A/I		GWH09AFA-K3NNA1A/I	
		Product Code	CA348N00400	CA348N00401	
1	Front Panel Assy	200003060038T	200003060038T	200003060038T	1
2	Display Board	300001000202	300001000202	300001000202	1
3	Filter Sub-Assy	11122472	11122472	11122472	2
4	Front Case Assy	000002060049	000002060049	000002060049	1
5	Axile Bush	10542036	10542036	10542036	1
6	Helicoid Tongue	200006000001	200006000001	200006000001	1
7	Left Axile Bush	10512037	10512037	10512037	1
8	Rear Case assy	1000062	000001000062	000001000062	1
9	Cross Flow Fan	10352067	10352067	10352067	1
10	O-Gasket sub-assy of Bearing	7651205102	76512051	76512051	1
11	Ring of Bearing	26152022	26152022	26152022	1
12	Evaporator Support	200025000002	200025000002	200025000002	1
13	Evaporator Assy	11001000123	011001000123	011001000123	1
14	Fan Motor	15012115	15012115	15012115	1
15	Wall Mounting Frame Sub-assy	17211000005	017211000005	017211000005	1
16	Connecting pipe clamp	200017000001	200017000001	200017000001	1
17	Rubber Plug (Water Tray)	76712012	76712012	76712012	1
18	Stepping Motor	1521210811	1521210811	1521210811	1
19	Crank	73012005	73012005	73012005	1
20	Drainage Hose	523001408	0523001408	0523001408	1
21	Electric Box Cover2	200082000005	200082000005	200082000005	1
22	Electric Box Assy	100002003122	100002061920	100002003240	1
23	Terminal Board	42010268	42010268	42010268	1
24	Main Board	30135000136	30135000145	30135000145	1
25	Power Cord	4002046439	4002046439	4002046439	1
26	Connecting Cable	40020540	40020540	40020540	0
27	Connecting Cable	40020536	40020536	40020536	0
28	Remote Controller	305001000009	305001000009	305001000009	1
29	Cold Plasma Generator	430001000001	/	/	1

Above data is subject to change without notice.

NO.	Description	Part Code		Qty
		GWH09AFB-K3NNA1A/I	GWH12AFB-K3NNA1A/I	
	Product Code	CA348N00300	CA348N00600	
1	Front Panel Assy	200003060037T	200003060037T	1
2	Display Board	300001000202	300001000202	1
3	Filter Sub-Assy	1112221905	1112221905	2
4	Front Case Assy	000002060048	000002060048	1
5	Axile Bush	10542036	10542036	1
6	Helicoid Tongue	200006000002	200006000002	1
7	Left Axile Bush	10512037	10512037	1
8	Rear Case assy	000001000061	000001000061	1
9	Cross Flow Fan	10352066	10352066	1
10	O-Gasket sub-assy of Bearing	7651205102	7651205102	1
11	Ring of Bearing	26152022	26152022	1
12	Evaporator Support	200025000002	200025000002	1
13	Evaporator Assy	011001000143	01100100014301	1
14	Fan Motor	150120874	150120874	1
15	Wall Mounting Frame Sub-assy	017211000005	017211000005	1
16	Connecting pipe clamp	200017000001	200017000001	1
17	Rubber Plug (Water Tray)	76712012	76712012	1
18	Stepping Motor	1521210811	1521210811	1
19	Crank	73012005	73012005	1
20	Drainage Hose	0523001408	0523001408	1
21	Electric Box Cover2	200082000005	200082000005	1
22	Electric Box Assy	100002003125	100002003690	1
23	Terminal Board	42010268	42010268	1
24	Main Board	30135000136	30135000145	1
25	Power Cord	4002046439	4002046439	1
26	Connecting Cable	40020540	40020540	0
27	Connecting Cable	40020536	40020536	0
28	Remote Controller	305001000009	305001000009	1
29	Cold Plasma Generator	430001000001	/	1

Above data is subject to change without notice.

NO.	Description	Part Code		Qty
		GWH12AFC-K3NNA1A/I	GWH18AFC-K3NNA1A/I	
	Product Code	CA348N00100	CA348N00700	
1	Front Panel	200003060035T	200003060035T	1
2	Display Board	300001000202	300001000202	1
3	Filter Sub-Assy	1112246803	1112246803	2
4	Screw Cover	242520179	242520179	1
5	Electric Box Cover Sub-Assy	0140206501	0140206501	1
6	Front Case Assy	000002060044	000002060044	1
7	Shield Cover of Electric Box Cover	01592150	01592150	1
8	Main Board	30135000071	30135000084	1
9	Electric Box Cover	20112207	20112207	1
10	Jumper	4202300119	4202300121	1
11	Terminal Board	42010268	42010268	1
12	Electric Box Assy	100002002958	100002003750	1
13	Axile Bush	10542036	10542036	1
14	Guide Louver	200004060017	200004060017	1
15	Crank	73012005	73012005	1
16	Stepping Motor	1521210703	1521210712	1
17	Rubber Plug (Water Tray)	76712012	76712012	1
18	Connecting pipe clamp	2611216401	2611216401	1
19	Fan Motor	15012146	15012146	1
20	Wall Mounting Frame	01252484	01252484	1
21	Cross Flow Fan	10352056	10352056	1
22	Evaporator Assy	01002976	01002695	1
23	Cold Plasma Generator	1114001603	/	1
24	Helicoid Tongue	26112436	26112436	1
25	Left Axile Bush	10512037	10512037	1
26	Rear Case assy	000001000054	000001000054	1
27	Drainage Hose	05230014	05230014	1
28	Ring of Bearing	26152022	26152022	1
29	O-Gasket sub-assy of Bearing	7651205102	7651205102	1
30	Evaporator Support 2	24212179	24212174	1
31	Remote Controller	305001000009	305001000009	1
32	Power Cord	4002046439	4002048740	1
33	Connecting Cable	40020540	400205401	0
34	Connecting Cable	40020536	40020536	0

Above data is subject to change without notice.

NO.	Description	Part Code		Qty
		GWH24AFD-K3NNA1A/I		
		Product Code	CA348N00502	
1	Front Panel	200003060039	200003060039	1
2	Display Board	300001000202	300001000202	1
3	Filter Sub-Assy	1112208906	1112208906	2
4	Screw Cover	242520179	242520179	1
5	Electric Box Cover Sub-Assy	20112209	20112209	1
6	Front Case Assy	000002060052	000002060052	1
7	Shield Cover of Electric Box Cover	01592176	01592176	1
8	Main Board	300002000744	300002000748	1
9	Electric Box Cover	20112209	20112209	1
10	Jumper	4202300102	4202300102	1
11	Terminal Board	4201026201	4201026201	1
12	Electric Box Assy	100002003770	100002003275	1
13	Axile Bush	10542036	10542036	1
14	Guide Louver	200004060019	200004060019	1
15	Crank	73012005	73012005	1
16	Stepping Motor	1521240210	1521240210	1
17	Rubber Plug (Water Tray)	76712012	76712012	1
18	Connecting pipe clamp	2611218801	2611218801	1
19	Fan Motor	1501214502	1501214502	1
20	Wall Mounting Frame	01362026	01362026	1
21	Cross Flow Fan	10352060	10352060	1
22	Evaporator Assy	01002686	01002686	1
23	Cold Plasma Generator	/	1114001602	1
24	Helicoid Tongue	26112512	26112512	1
25	Left Axile Bush	10512037	10512037	1
26	Rear Case assy	000001000009	000001000009	1
27	Drainage Hose	05230014	05230014	1
28	Ring of Bearing	26152025	26152025	1
29	O-Gasket sub-assy of Bearing	76512051	76512051	1
30	Evaporator Support 2	24212177	24212177	1
31	Remote Controller	305001000009	305001000009	1
32	Power Cord	4002048716	4002048716	1
33	Connecting Cable	400205382	400205382	0
34	Connecting Cable	40020536	40020536	0

Above data is subject to change without notice.

10.2 Outdoor Unit

GWH07ACA-K3NNA5A/O
GWH09ACB-K3NNA5A/O

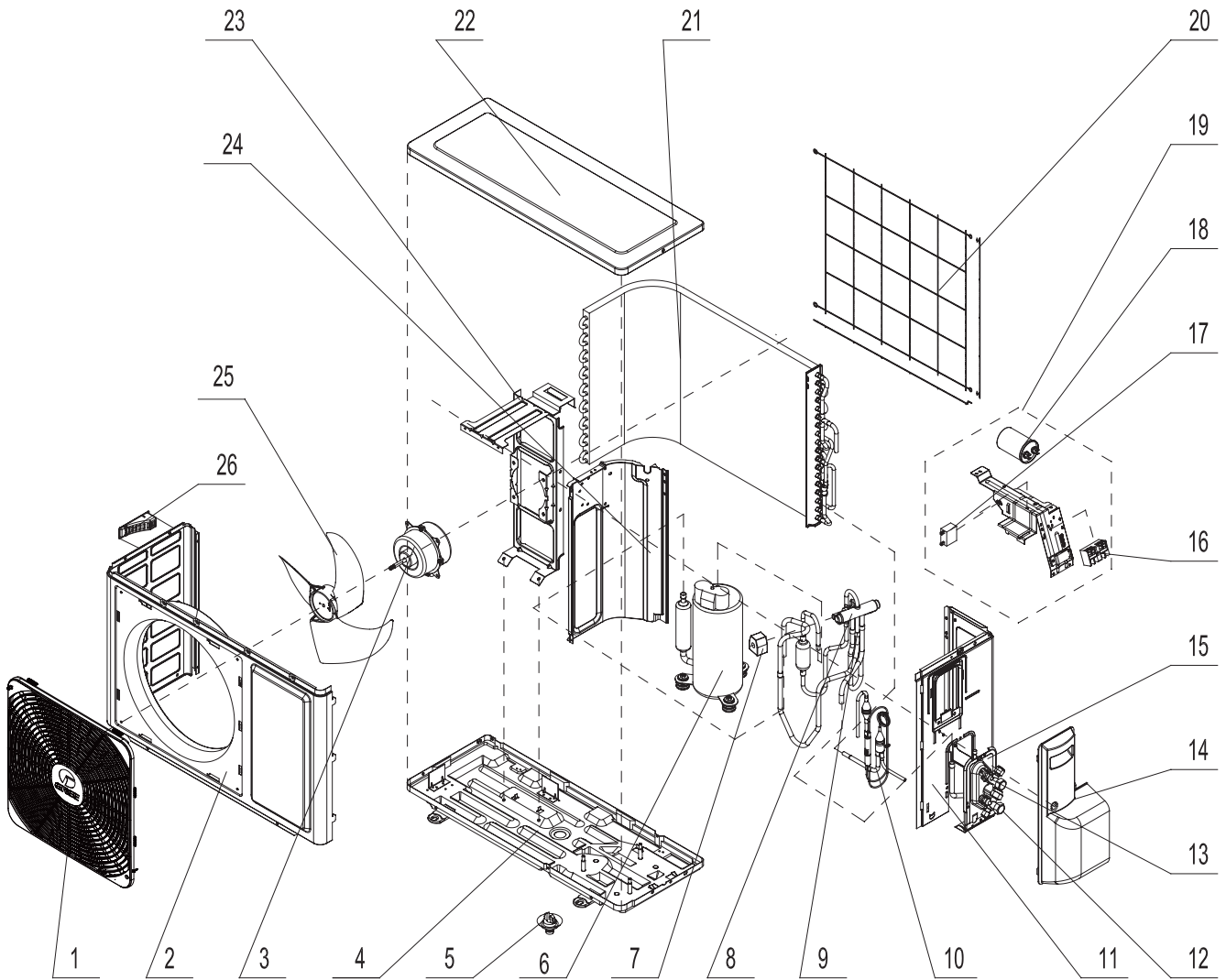

The component picture is only for reference; please refer to the actual product.

NO.	Description	Part Code		Qty
		GWH07ACA-K3NNA5A/O	GWH09ACB-K3NNA5A/O	
	Product Code	CA341W00100	CA341W00200	
1	Front Grill	22413030	22413030	1
2	Cabinet	01533255P	01533255P	1
3	Fan Motor	1501315604	1501315604	1
4	Chassis Sub-assy	017000000107	017000000112P	1
5	Drainage Connector	06123401	06123401	1
6	Compressor and Fittings	009001000075	009001000025	1
7	Magnet Coil	4300040047	4300040047	1
8	4-Way Valve	430004022	430004022	1
9	4-Way Valve Assy	030152000119	030152000203	1
10	Capillary Sub-assy	030006000201	030006000277	1
11	Right Side Plate Sub-Assy	01303243	01303243	1
12	Valve	07130239	07130239	1
13	Valve	07100005	07100005	1
14	Big Handle	26233101	2623304202	1
15	Valve Support	01713424	01713041	1
16	Terminal Board	42010265	42010265	1
17	Capacitor CBB61S	3301074701	3301074701	1
18	Capacitor CBB65	3300008102	33000081	1
19	Electric Box Assy	100002000395	100002000477	1
20	Rear Grill	01473041	01473041	1
21	Condenser Assy	011002000217	011002000294	1
22	Top Cover Plate	01253045P	01253045P	1
23	Motor Support Sub-Assy	01703204	01703204	1
24	Clapboard Sub-Assy	01233207	01233207	1
25	Axial Flow Fan	10333002	10333002	1
26	Small Handle	26233100	26233100	1

Above data is subject to change without notice.

GWH09AAA-K3NNA1A/O

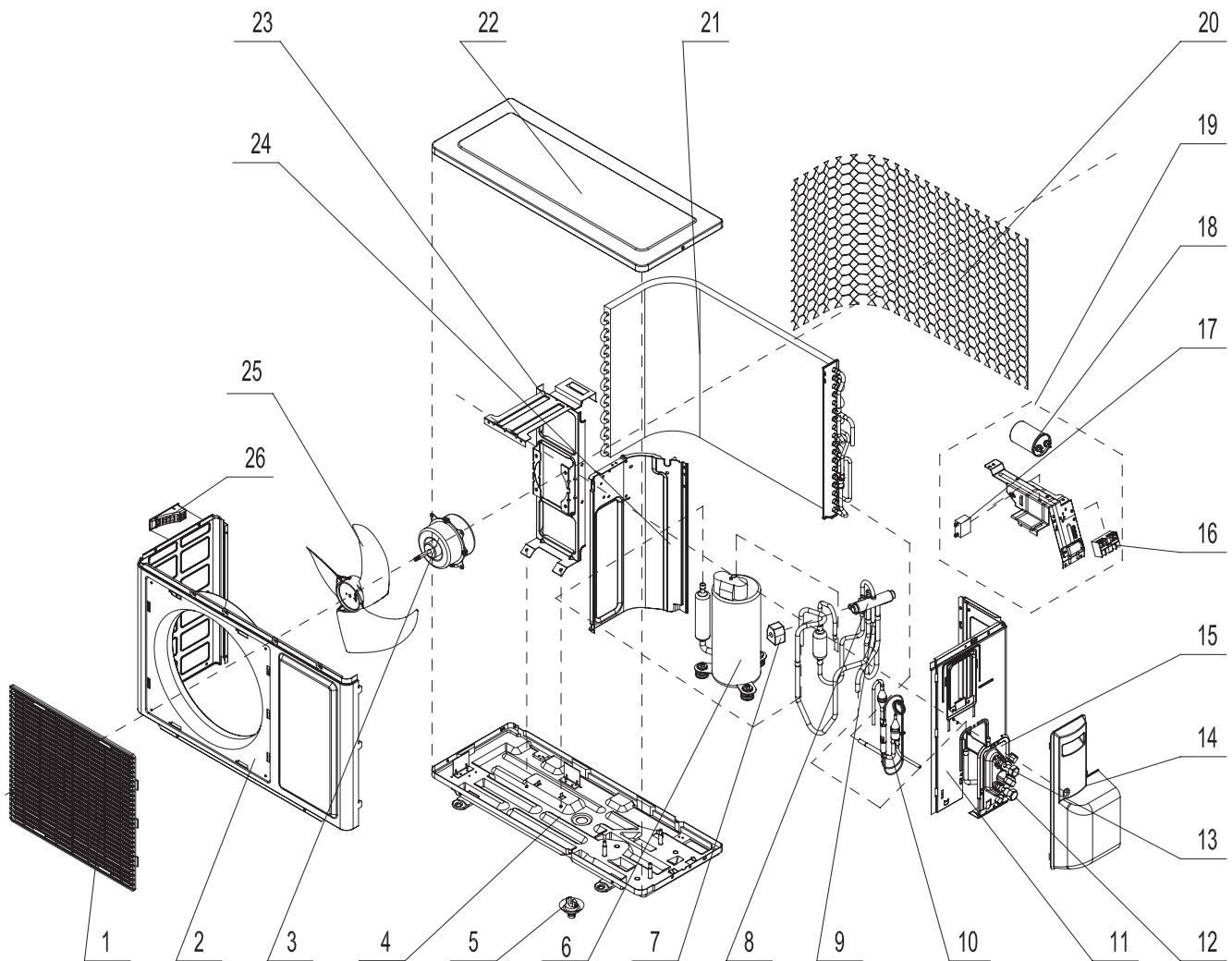

The component picture is only for reference; please refer to the actual product.

NO.	Description	Part Code	Qty
		GWH09AAA-K3NNA1A/O	
	Product Code	CA115W14400	
1	Front Grill	22263002	1
2	Cabinet	01533255P	1
3	Fan Motor	1501315604	1
4	Chassis Sub-assy	017000000112P	1
5	Drainage Connector	06123401	1
6	Compressor and Fittings	009001000025	1
7	Magnet Coil	4300040047	1
8	4-Way Valve	430004022	1
9	4-Way Valve Assy	030152000203	1
10	Capillary Sub-assy	030006000277	1
11	Right Side Plate Sub-Assy	01303243	1
12	Valve	07130239	1
13	Valve	07100005	1
14	Big Handle	2623304202	1
15	Valve Support	01713041	1
16	Terminal Board	42010265	1
17	Capacitor CBB61S	3301074701	1
18	Capacitor CBB65	33000081	1
19	Electric Box Assy	100002000477	1
20	Rear Grill	11123204	1
21	Condenser Assy	011002000294	1
22	Top Cover Plate	01253045P	1
23	Motor Support Sub-Assy	01703204	1
24	Clapboard Sub-Assy	01233207	1
25	Axial Flow Fan	10333002	1
26	Small Handle	26233100	1

Above data is subject to change without notice.

GWH12QC-K3NNA1A/O

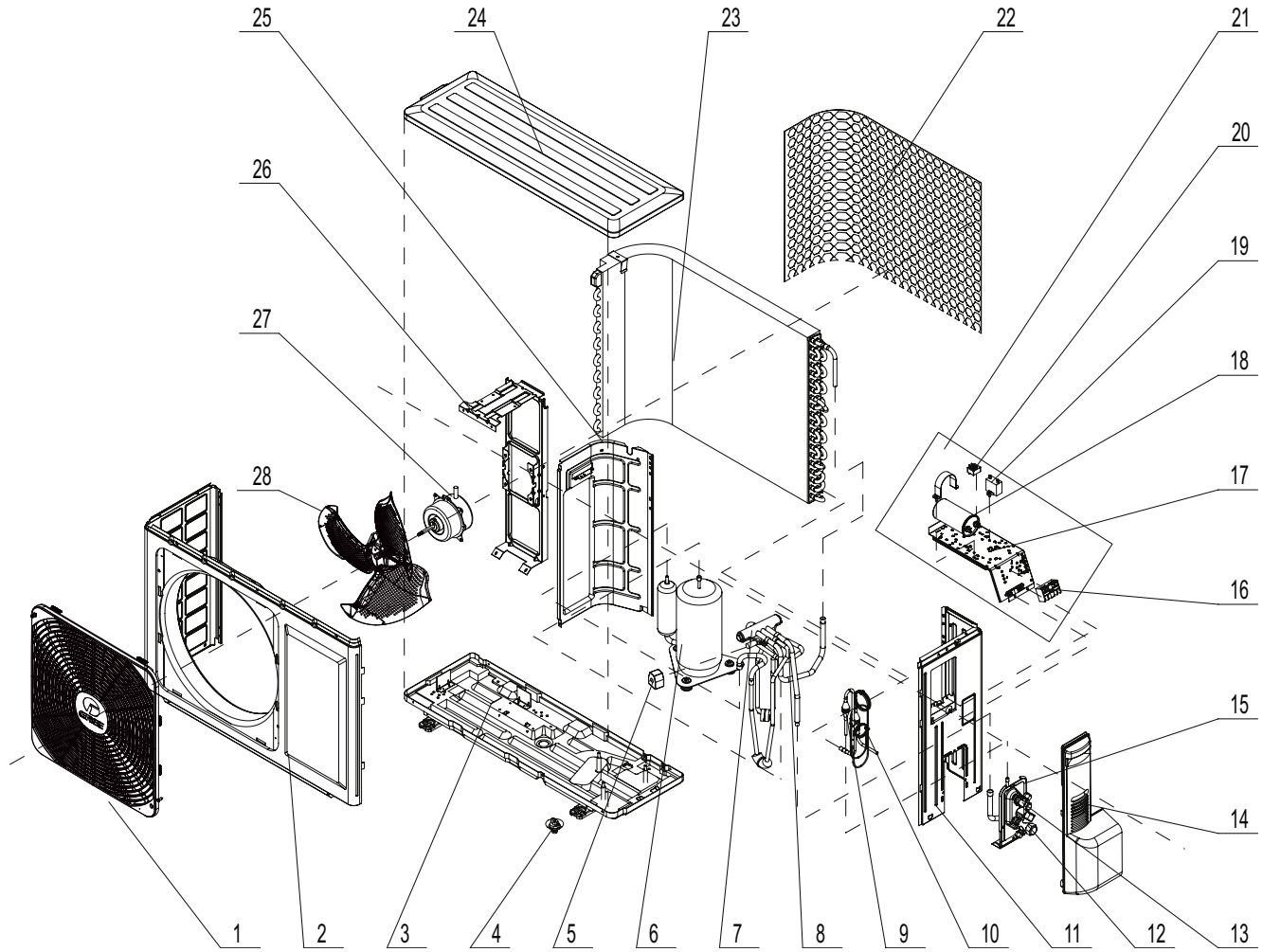

The component picture is only for reference; please refer to the actual product.

NO.	Description	Part Code	Qty
		GWH12QC-K3NNA1A/O	
	Product Code	CA419W00101	
1	Front Grill	22413049	1
2	Front Panel	0153303204P	1
3	Chassis Sub-assy	02803307P	1
4	Drainage Connector	06123401	1
5	Magnet Coil	43000400	1
6	Compressor and Fttings	00103781G	1
7	4-way Valve	03073110	1
8	4-way Valve Assy	430004022	1
9	StrainerA	07210022	1
10	Capillary Sub-Assy	03163251	1
11	Right Side Plate Assy	0130200404	1
12	Valve	07100003	1
13	Valve	07100006	1
14	Big Handle	262334332	1
15	Valve Support	01713041	1
16	Terminal Board	420001000003	1
17	Electric Box Sub-Assy	01403117	1
18	Capacitor CBB65	3300008109	1
19	Capacitor CBB61	3301074702	1
20	Terminal Board	/	/
21	Electric Box Assy	100002060796	1
22	Rear grill	01473057	1
23	Condenser Assy	01163857	1
24	Top Cover Plate	01253107P	1
25	Clapboard Sub-Assy	017021000152	1
26	Motor Support Sub-Assy	01703104	1
27	Fan Motor	150130672	1
28	Axial Flow Fan	10333004	1

Above data is subject to change without notice.

GWH18AAC-K3NNA1A/O

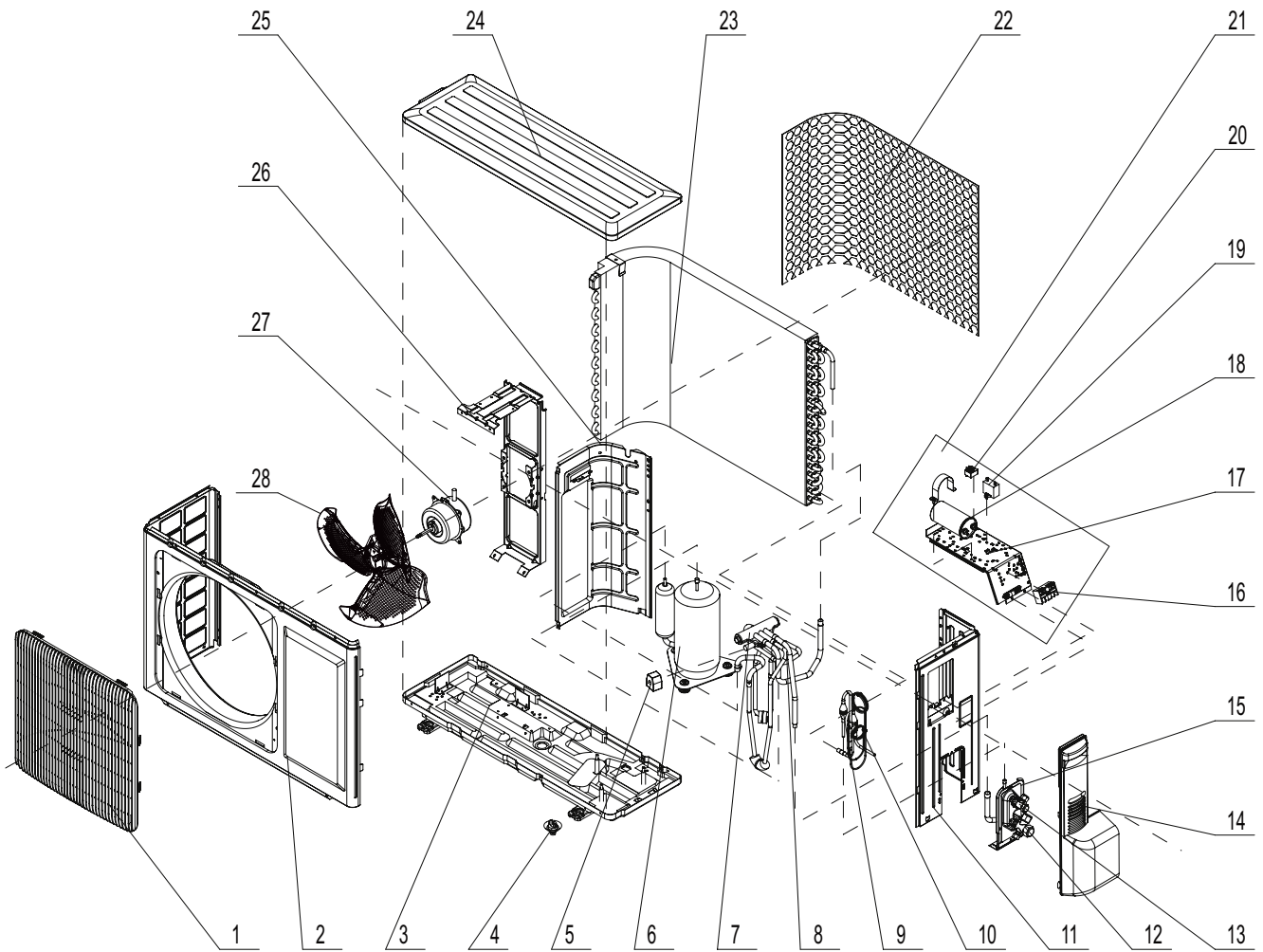

The component picture is only for reference; please refer to the actual product.

NO.	Description	Part Code	Qty
		GWH18AAC-K3NNA1A/O	
	Product Code	CA115W14200	
1	Front Grill	22413008	1
2	Front Panel	0153304702	1
3	Chassis Sub-assy	017000000042	1
4	Drainage Connector	06123401	1
5	Magnet Coil	4300040047	1
6	Compressor and Fttings	009001000074	1
7	4-way Valve	430004032	1
8	4-way Valve Assy	030152000185	1
9	StrainerA	07210022	1
10	Capillary Sub-Assy	030006000254	1
11	Right Side Plate Assy	0130200404	1
12	Valve	07100003	1
13	Valve	07100006	1
14	Big Handle	262334332	1
15	Valve Support	01713041	1
16	Terminal Board	420001000003	1
17	Electric Box Sub-Assy	02613089	1
18	Capacitor CBB65	3300008104	1
19	Capacitor CBB61	3301074710	1
20	Terminal Board	/	/
21	Electric Box Assy	100002000583	1
22	Rear grill	11123205	1
23	Condenser Assy	011002000273	1
24	Top Cover Plate	01253443	1
25	Clapboard Sub-Assy	012334172	1
26	Motor Support Sub-Assy	0170310401	1
27	Fan Motor	150130676	1
28	Axial Flow Fan	10333427	1

Above data is subject to change without notice.

GWH12AAB-K3NNA2A/O

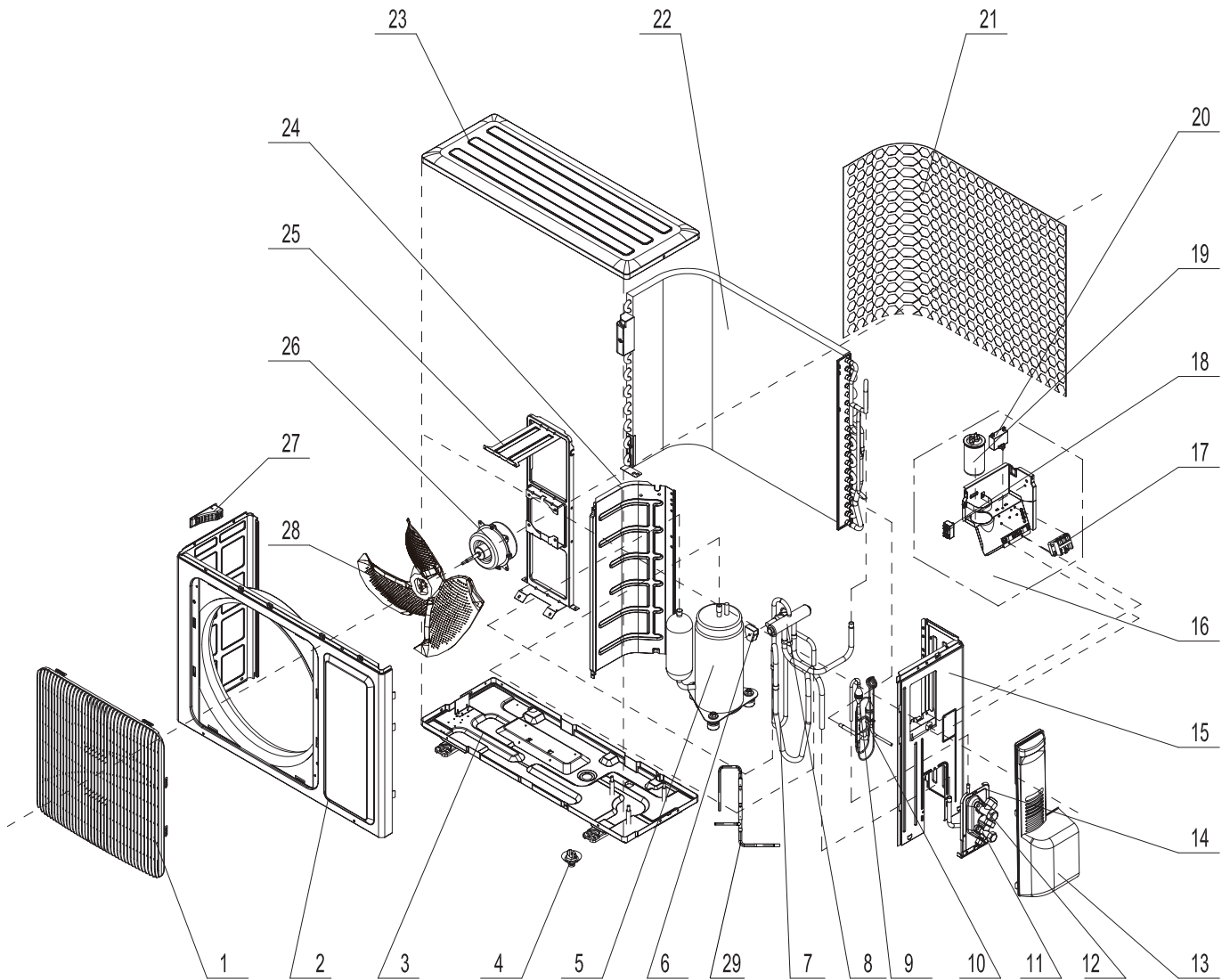

The component picture is only for reference; please refer to the actual product.

No.	Description	Part Code	Qty
		GWH12AAB-K3NNA2A/O	
Product Code		CA115W14100	
1	Front grill	22413008	1
2	Front Panel	01533034P	1
3	Chassis Sub-assy	01700000168	1
4	Drainage Connector	06123401	1
5	Compressor and fittings	009001000024	1
6	Magnet Coil	4300040047	1
7	4-way Valve Assy	030152000222	1
8	4-way Valve	430004022	1
9	Strainer	07210022	1
10	Capillary Sub-Assy	030006000259	1
11	Valve	07100003	1
12	Valve	0713386901	1
13	Big Handle	262334332	1
14	Valve Support	0170308901P	1
15	Right Side Plate Sub-Assy	0130200404	1
16	Electric Box Assy	100002000615	1
17	Terminal Board	420001000003	1
18	Terminal Board	42011147	1
19	Capacitor CBB65	3300008101	1
20	Capacitor CBB61	3301074710	1
21	Rear grill	1112320501	1
22	Condenser Assy	011002000277	1
23	Top Cover Sub-Assy	0125309901	1
24	Clapboard Sub-Assy	01233066	1
25	Motor Support	01703104	1
26	Fan Motor	150130676	1
27	Small Handle	26233100	1
28	Axial Flow Fan	10333427	1
28	Throttle Valve Sub-assy	/	/

Above data is subject to change without notice.

GWH24AAD-K3NNA1A/O(CA115W14300)

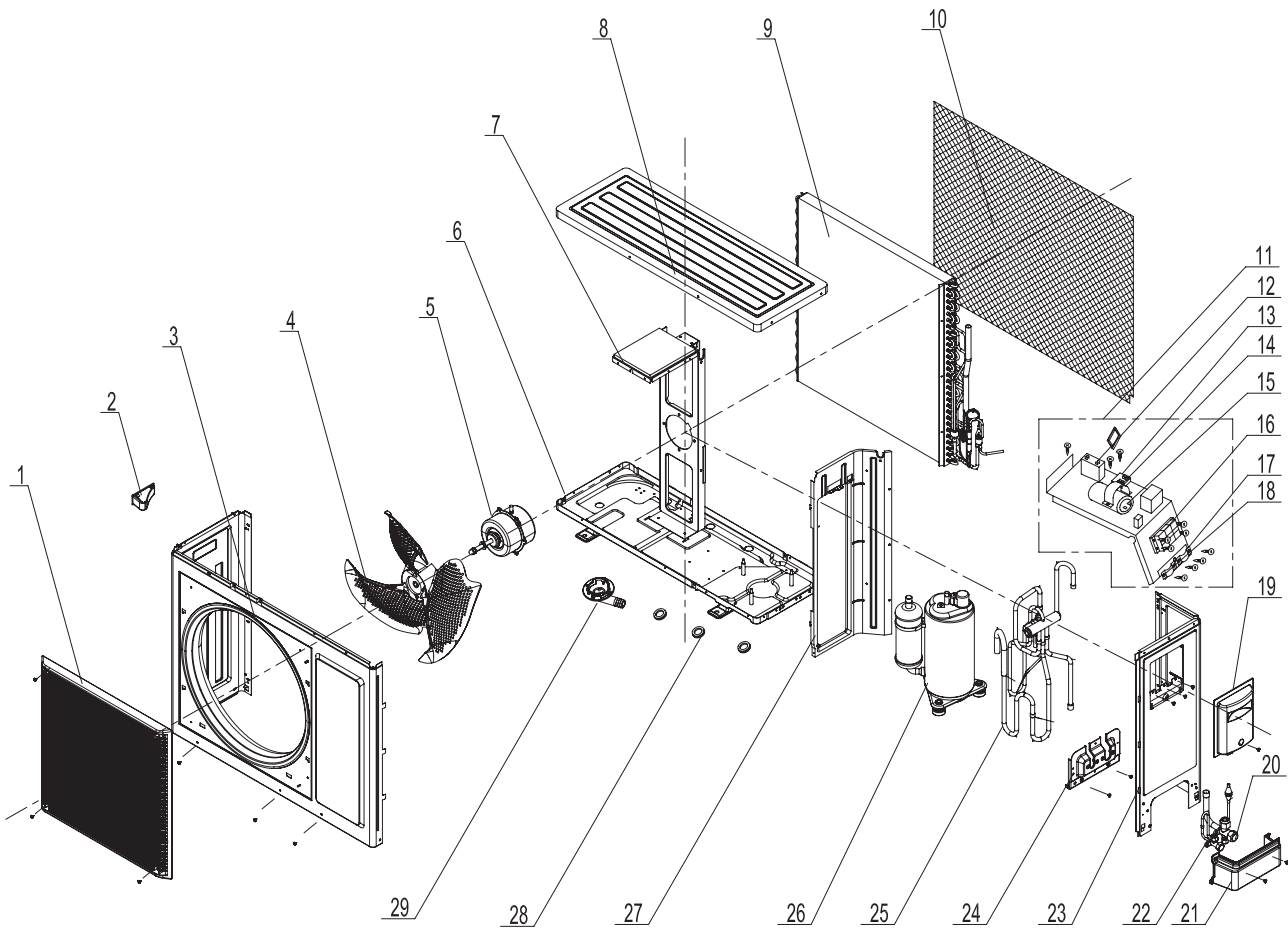

The component picture is only for reference; please refer to the actual product.

NO.	Description	Part Code	Qty
		GWH24AAD-K3NNA1A/O	
	Product Code	CA115W14300	
1	Front Grill	22415001	1
2	Left Handle	/	/
3	Cabinet	01435001P	1
4	Axial Flow Fan	10335261	1
5	Fan Motor	15015057	1
6	Chassis Sub-assy	02803108P	1
7	Motor Support Sub-Assy	0170305901	1
8	Coping	01255001	1
9	Condenser Assy	01163524	1
10	Rear Grill	01473069	1
11	Electric Box Assy	100002000839	1
12	AC Contactor	44010245	1
13	Capacitor CBB65	3300008105	1
14	Capacitor Clamp	02141375	1
15	Capacitor CBB61	3301074710	1
16	Terminal Board	42010194	1
17	Wire Clamp	71010102	1
18	Wire Clamp	71010103	1
19	Handle	26235253	1
20	Cut off Valve	07130213	1
21	Valve Cover	22243003	1
22	Cut off Valve	07100003	1
23	Right Side Plate	01305095P	1
24	Valve Support Sub-Assy	01713075	1
25	4-Way Valve Assy	030152000220	1
26	Compressorand Fittings	00103872	1
27	Clapboard Sub-Assy	01233035	1
28	Drainage Plug	06813401	3
29	Drainage Connector	06123401	1

Above data is subject to change without notice.

GWH24AAD-K3NNA1A/O(CA115W14301)

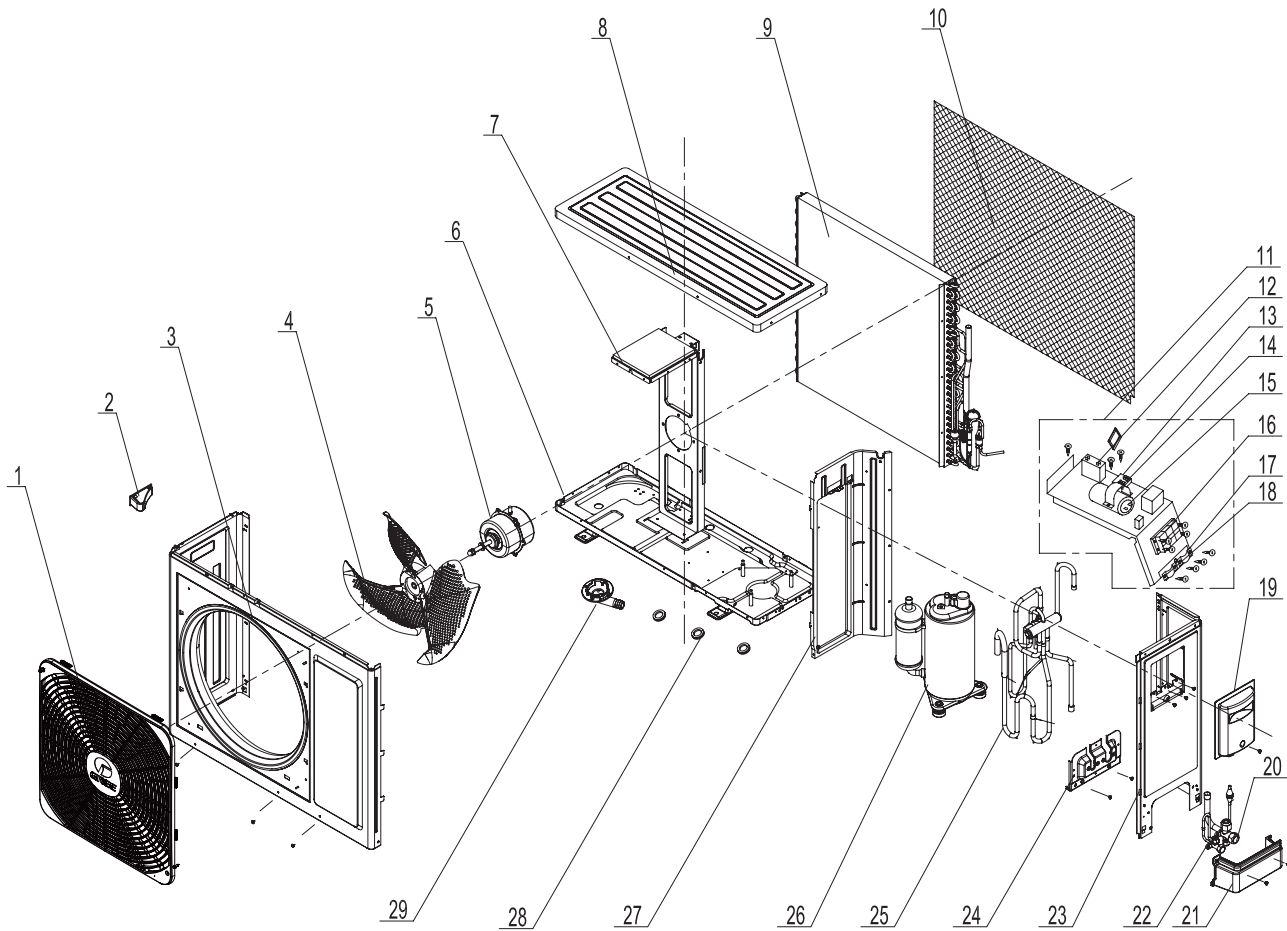

The component picture is only for reference; please refer to the actual product.

NO.	Description	Part Code	Qty
		GWH24AAD-K3NNA1A/O	
		Product Code CA115W14301	
1	Front Grill	22413029	1
2	Left Handle	/	/
3	Cabinet	01435001P	1
4	Axial Flow Fan	10335261	1
5	Fan Motor	15015057	1
6	Chassis Sub-assy	02803108P	1
7	Motor Support Sub-Assy	0170305901	1
8	Coping	01255001	1
9	Condenser Assy	01163524	1
10	Rear Grill	01473072	1
11	Electric Box Assy	100002000839	1
12	AC Contactor	44010245	1
13	Capacitor CBB65	3300008105	1
14	Capacitor Clamp	02141375	1
15	Capacitor CBB61	3301074710	1
16	Terminal Board	4201026201	1
17	Wire Clamp	71010102	1
18	Wire Clamp	71010103	1
19	Handle	2623525404	1
20	Cut off Valve	07130213	1
21	Valve Cover	22243003	1
22	Cut off Valve	07130213	1
23	Right Side Plate	01305095P	1
24	Valve Support Sub-Assy	01713075	1
25	4-Way Valve Assy	030152000220	1
26	Compressorand Fittings	00103872	1
27	Clapboard Sub-Assy	01233035	1
28	Drainage Plug	06813401	3
29	Drainage Connector	06123401	1

Above data is subject to change without notice.

11. Removal Procedure

11.1 Removal Procedure of Indoor Unit

 **Caution: discharge the refrigerant completely before removal.**

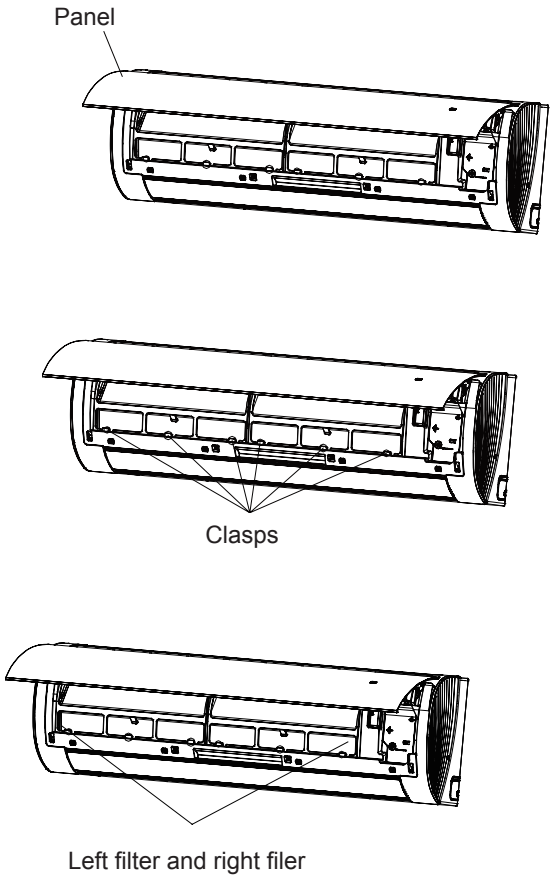
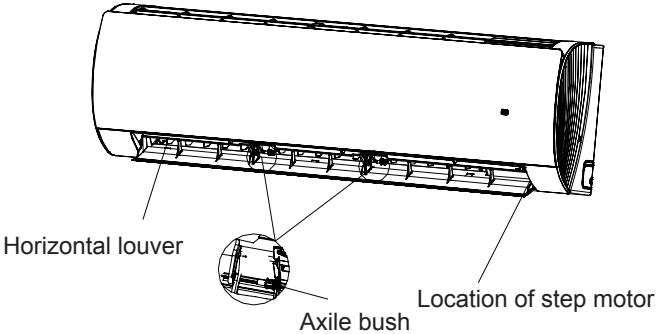
Step	Procedure	Procedure
1. Remove filter	<p>a Open the panel.</p> <p>b Loosen the clasp shown in the fig and then pull the left filter and right filter outwards to remove them.</p>	 <p>Panel</p> <p>Clasps</p> <p>Left filter and right filter</p>
2. Remove horizontal louver	<p>Push out the axle bush on horizontal louver. Bend the horizontal louver with hand and then separate the horizontal louver from the crankshaft of step motor to remove it.</p>	 <p>Horizontal louver</p> <p>Axile bush</p> <p>Location of step motor</p>

Step	Procedure	Image
3. Remove panel	<p>Open the front panel; separate the panel rotation shaft from the groove fixing the front panel and then removes the front panel.</p> <p>Note: The display of some models is fixed on the panel; unscrew the screws fixing the display on the panel before removing the panel.</p>	
4. Remove electric box cover 2	<p>Remove the screws on the electric box cover 2 to remove the electric box cover 2.</p>	
5. Remove front case sub-assy	<p>a Remove the screws fixing front case.</p> <p>Note: (1) Open the screw caps before removing the screws around the air outlet. (2) The quantity of screws fixing the front case sub-assy is different for different models.</p> <p>b Loosen the clasps at left, middle and right sides of front case. Lift the front case sub-assy upwards to remove it.</p>	

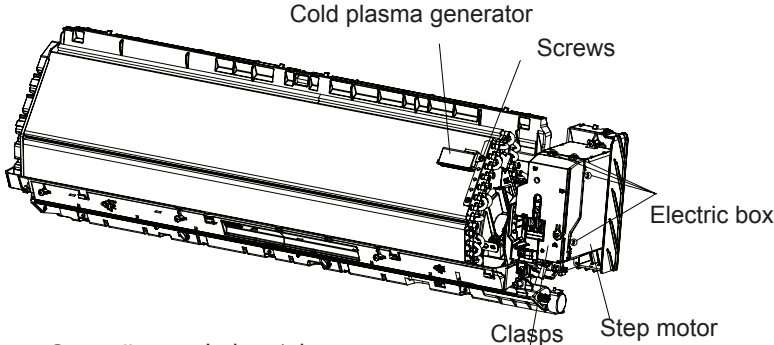
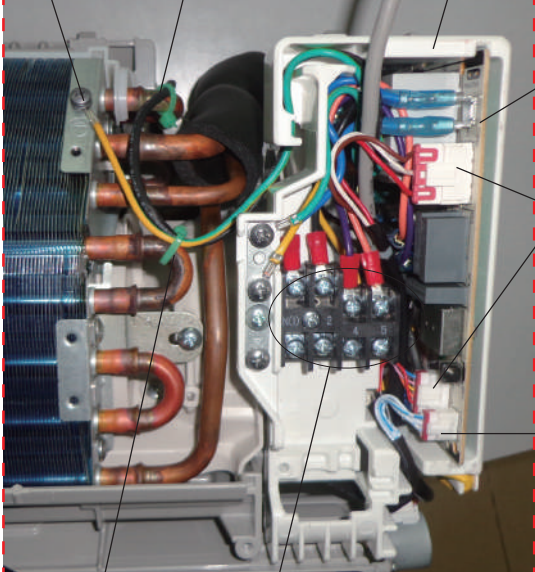
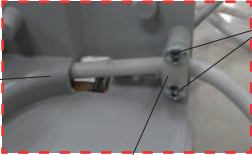
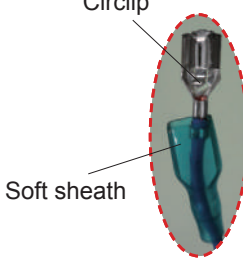
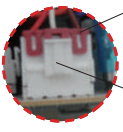
Step	Procedure
6. Remove electric box assy	
<p>a</p> <p>Loosen the connection clasps between Cold plasma generator and electric box, and then remove the cold plasma generator.</p> <p>b</p> <ol style="list-style-type: none"> ① Cut off the wire binder and pull out the indoor tube temperature sensor. ② Screw off one grounding screw. ③ Remove the wiring terminals of motor andstepping motor. ④ Remove the electric box assy. ⑤ Screw off the screws that are locking each. 	
<p>c</p> <p>Rotate the electric box assy. Twist off the screws that are locking the wire clip and loosen the power cord. Remove the wiring terminal of power cord. Lift up the main board and take it off.</p> <p>Instruction: Some wiring terminal of this product is with lock catch and other devices. The pulling method is as below:</p> <ol style="list-style-type: none"> 1.Remove the soft sheath for some terminals at first, hold the circlip and then pull out the terminals. 2.Pull out the holder for some terminals at first (holder is not available for some wiring terminal), hold the connector and then pull the terminal. 	  

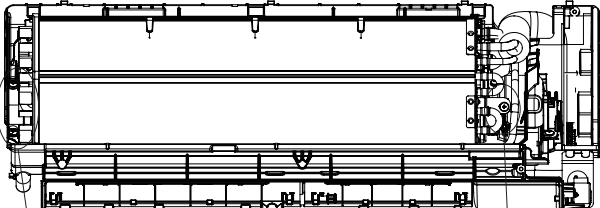
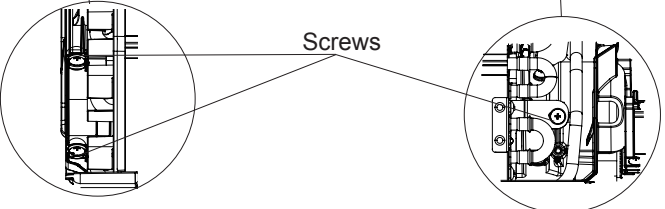
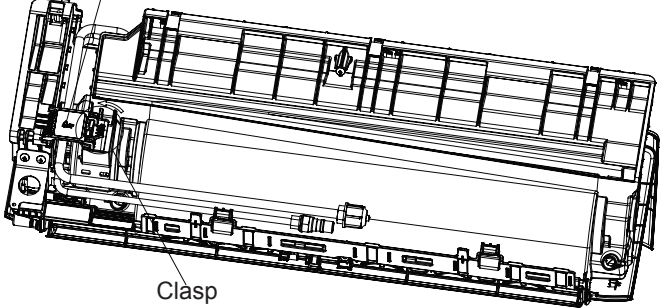
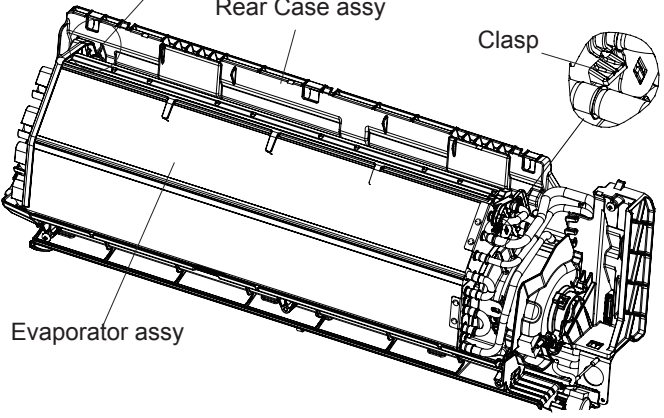
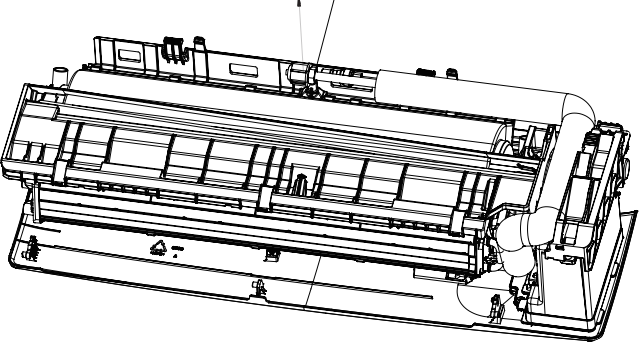
Step	Procedure	Image
7. Remove evaporator assy		
a	Remove 3 screws fixing evaporator assy.	 <p style="text-align: center;">Screws</p>
b	At the back of the unit, Loosen the clasp, connection pipe clamp and then remove the connection pipe clamp.	 <p style="text-align: center;">Connection pipe clamp</p>
c	First remove the left side of evaporator from the groove of bottom shell and then remove the right side from the clasp on the bottom shell.	 <p style="text-align: center;">Groove Rear Case assy Clasp</p> <p style="text-align: center;">Evaporator assy</p>
d	Adjust the position of connection pipe on evaporator slightly and then lift the evaporator upwards to remove it.	 <p style="text-align: center;">Connection pipe</p>

Step	Procedure
<p>8. Remove motor and cross flow blade</p> <p>a Remove 3 screws fixing motor clamp and then remove the motor clamp.</p> <p>b Remove the at the connection place of cross flow blade and motor; lift the motor and cross flow blade upwards to remove them.</p>	<p>The diagram illustrates the removal of the motor and cross flow blade in three stages. The top illustration shows the motor clamp being removed from the unit, with labels for 'Motor clamp' and 'Screws'. The middle illustration shows the cross flow blade and motor being separated, with labels for 'Cross flow' and 'Motor'. The bottom illustration shows the unit with the motor and cross flow blade removed.</p>
<p>9. Remove vertical louver</p>	<p>Loosen the connection clasps between vertical louver and bottom case to remove vertical louver.</p> <p>The diagram illustrates the removal of the vertical louver in two stages. The top illustration shows the vertical louver being lifted away from the bottom case, with a label for 'Clasps'. The bottom illustration shows the bottom case with the clasps removed, with a label for 'Clasps'.</p>

11.2 Removal Procedure of Outdoor Unit

07/09K

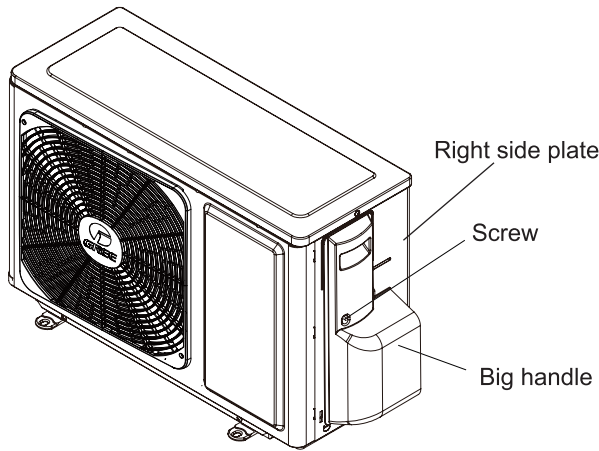
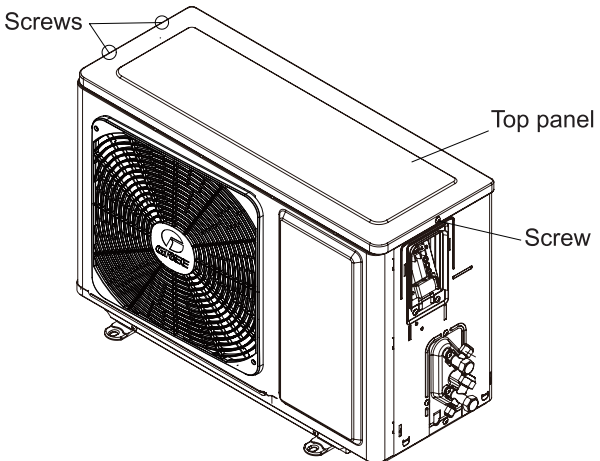
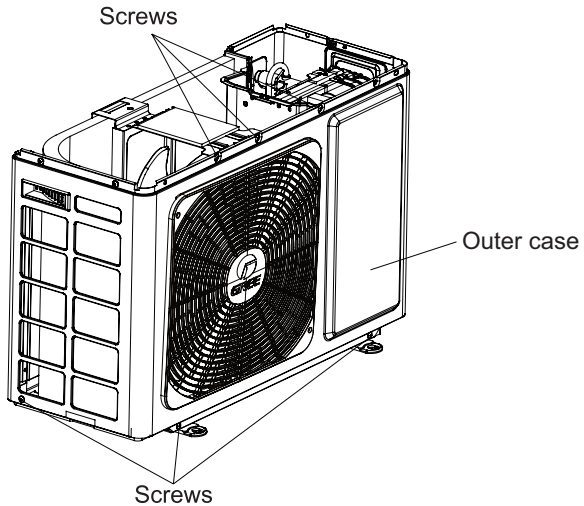
Step	Procedure
1. Remove big handle	<p data-bbox="251 436 714 589">Remove the screw fixing big handle; slide out the big handle upwards to make the clasp of big handle separate from the groove of right side plate, and then remove the big handle.</p>  A perspective view of the outdoor unit. A rectangular handle is attached to the right side of the unit. A screw is shown passing through the handle into the side panel. Labels with leader lines point to the 'Right side plate', the 'Screw', and the 'Big handle'. The fan grille is visible on the left side.
2. Remove top panel	<p data-bbox="251 982 682 1048">Remove the screws fixing top panel and then remove the top panel.</p>  A perspective view of the outdoor unit with the top panel partially detached. Two screws are shown being removed from the top surface of the panel. Labels with leader lines point to the 'Screws', the 'Top panel', and a 'Screw' on the side panel. The fan grille is visible on the left side.
3. Remove outer case	<p data-bbox="251 1583 682 1648">Remove the screws fixing the outer case and then remove the outer case.</p>  A perspective view of the outdoor unit with the outer case removed. The case is shown as a separate grid-like structure to the left of the unit. Screws are shown being removed from the top of the unit. Labels with leader lines point to the 'Screws' and the 'Outer case'. The fan grille is visible on the left side.

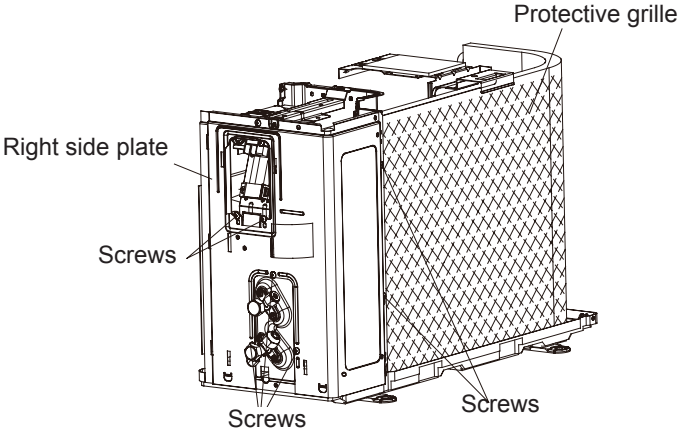
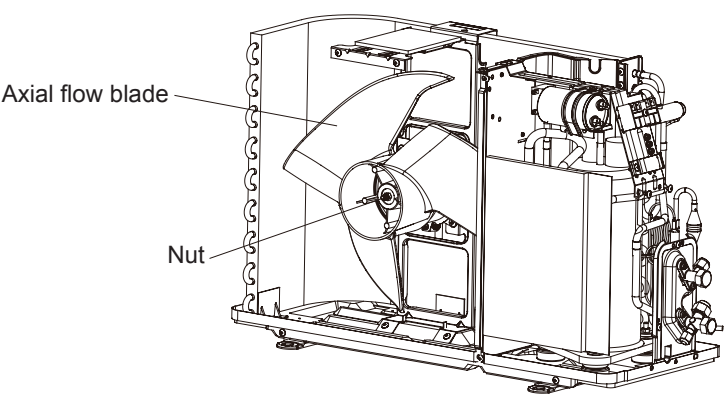
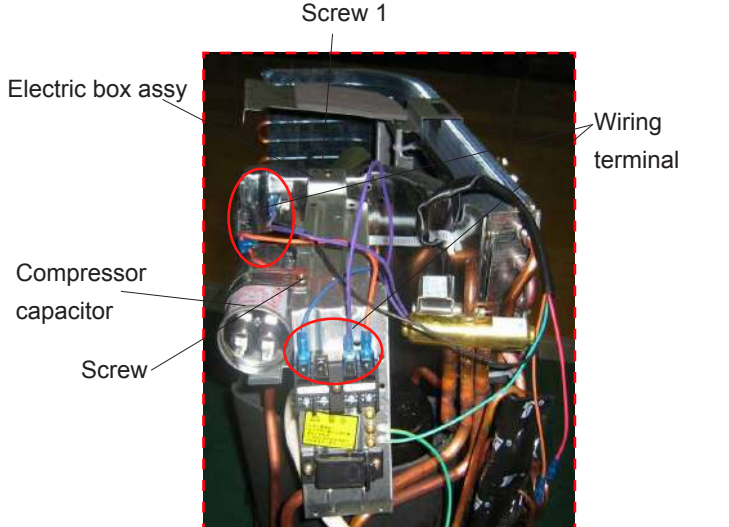
Step	Procedure
<p>4. Remove right side plate</p>	<p>Remove the screws fixing right side plate and then remove the right side plate.</p> <p>Cut off the wire binder fixing the protective grille and then remove the protective grille.</p> 
<p>5. Remove axial flow blade</p>	<p>Remove the nut fixing axial flow blade and then remove the axial flow blade.</p> 
<p>6. Remove electric box assy</p>	<p>Remove the wiring terminals on electric box. Screw off screw 1 fixing the electric box assy and then remove the electric box assy. Screw off the screws fixing compressor capacitor. Then remove the compressor capacitor.</p> 

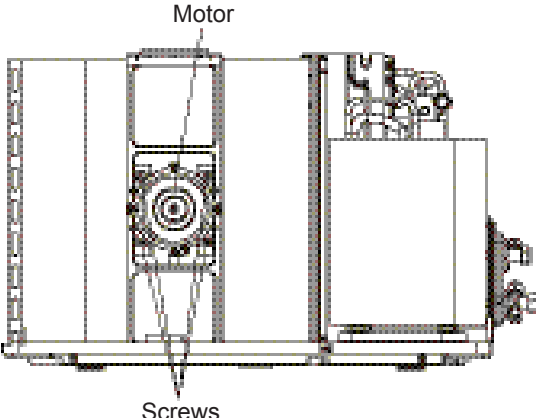
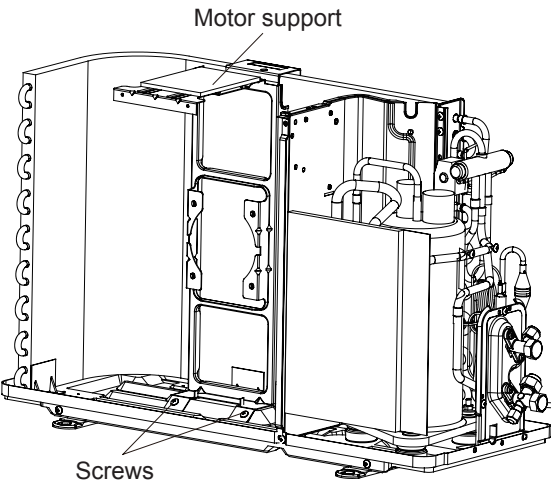
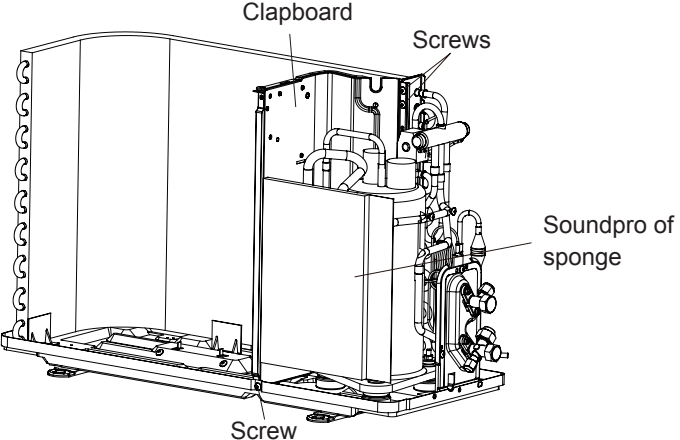
Step	Procedure
7. Remove motor	<p>Remove the screws fixing motor and then remove the motor.</p> 
8. Remove motor support	<p>Remove the screws fixing motor support and then remove the motor support.</p> 
9. Remove clapboard and soundproof sponge	<p>Remove the screws fixing clapboard and then remove the clapboard.</p> <p>Remove the soundproof sponge wrapping the compressor.(Some models are without soundproof sponge)</p> 

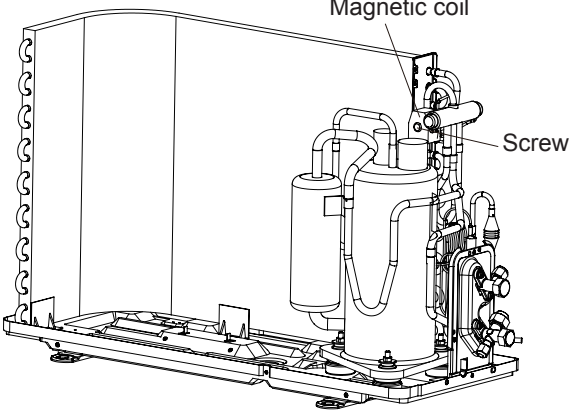
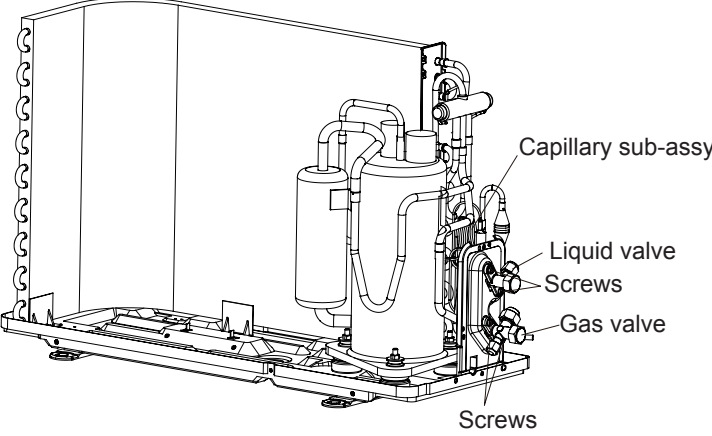
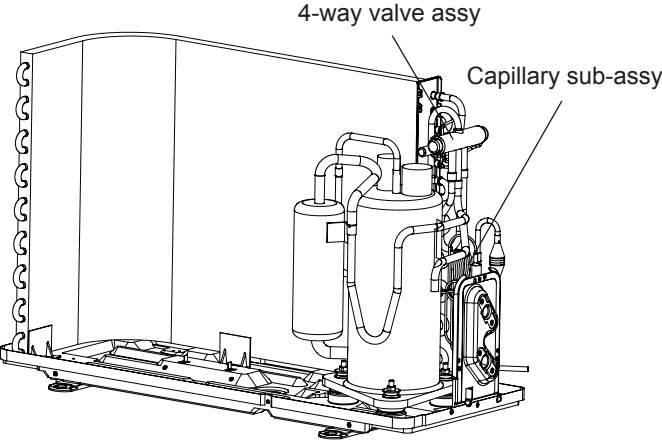
Step	Procedure
10. Remove magnetic coil	<p>Remove one screw on magnetic coil, and then remove the magnetic coil.</p>  <p>The diagram shows a side view of the magnetic coil assembly. A line points to a screw on the top of the coil, labeled 'Screw'. Another line points to the coil itself, labeled 'Magnetic coil'.</p>
11. Remove gas valve and liquid valve	<p>Unsolder the spot weld between capillary with valve and condenser; remove two screws fixing the gas valve; unsolder the spot weld connecting gas valve and air-return pipe, and then remove the gas valve.</p> <p>Remove two screws fixing the liquid valve; unsolder the spot weld connecting liquid valve and Y-type pipe, and then remove the liquid valve.</p> <p>Note: When unsoldering the spot weld, wrap the gas valve with wet cloth completely to avoid damaging the valve due to high temperature.</p>  <p>The diagram shows the gas and liquid valve assemblies. Labels include: 'Capillary sub-assy' pointing to the top connection, 'Liquid valve' pointing to the lower valve, 'Screws' pointing to the screws on the liquid valve, and 'Gas valve' pointing to the right-side valve. There are also 'Screws' labeled at the bottom of the assembly.</p>
12. Remove 4-way valve assy and capillary sub-assy	<p>Unsolder the spot weld of 4-way valve assy, capillary, compressor and condenser, and then remove the 4-way valve assy and capillary sub-assy.</p> <p>Note: When unsoldering the spot weld, wrap the 4-way valve with wet cloth completely to avoid damaging the valve due to high temperature.</p>  <p>The diagram shows the 4-way valve assembly and capillary sub-assembly. Labels include: '4-way valve assy' pointing to the top valve assembly and 'Capillary sub-assy' pointing to the lower capillary assembly.</p>

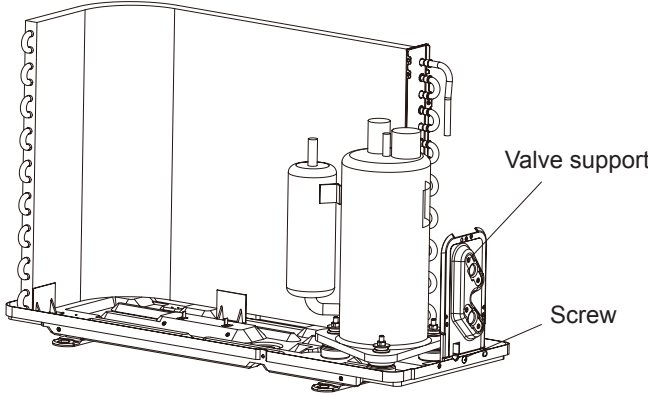
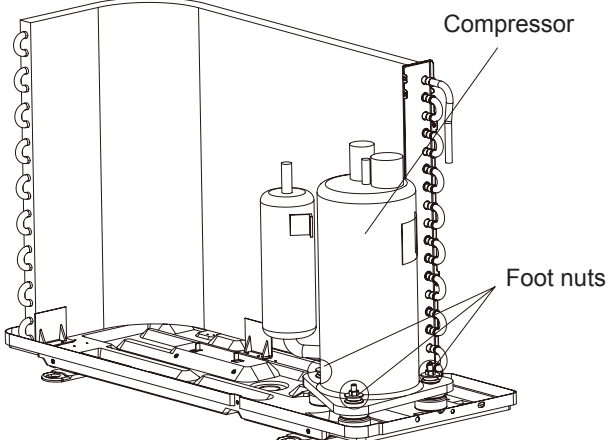
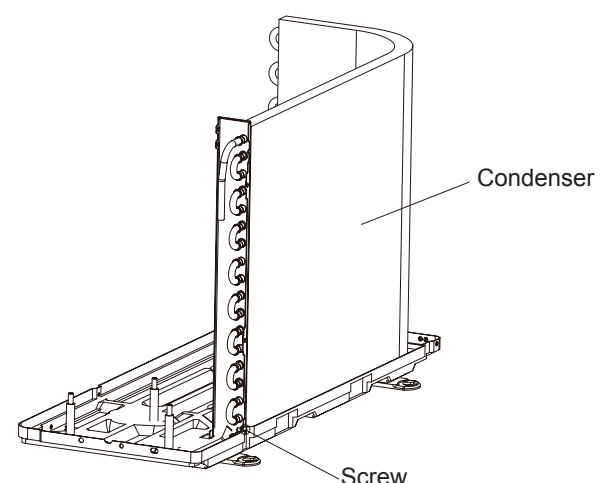
Step	Procedure	Diagram
13. Remove valve support	<p>Screw off the screw fixing the valve support and then remove the valve support.</p>	 <p>Valve support</p> <p>Screw</p>
14. Remove compressor	<p>Remove 3 foot nuts on compressor, and then remove the compressor.</p> <p>Note: Protect the ports of discharge pipe and suction pipe to avoid foreign objects to enter it.</p>	 <p>Compressor</p> <p>Foot nuts</p>
15. Remove condenser	<p>Remove one screw fixing the condenser, then remove the condenser.</p>	 <p>Condenser</p> <p>Screw</p>

GWH12QC-K3NNA1A/O GWH18AAC-K3NNA1A/O

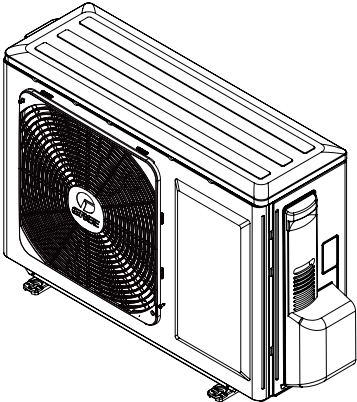
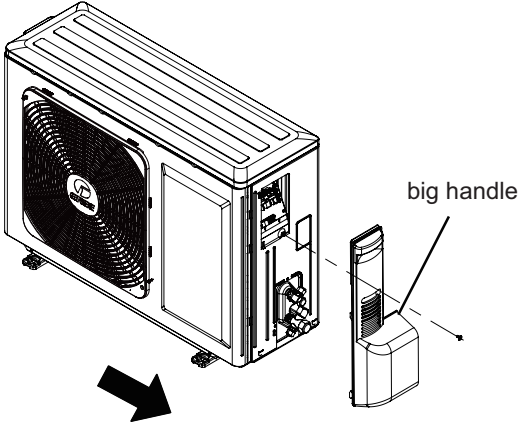
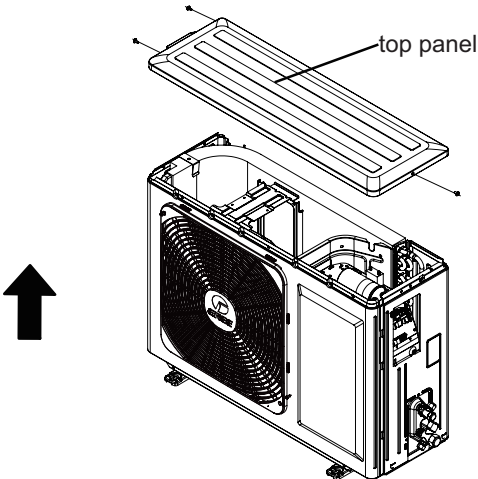
Steps	Procedure
<p>1. Before disassembly</p>	
<p>2. Remove big handle</p>	<p>Remove the connection screw fixing the big handle and then remove the handle.</p> 
<p>3. Remove top cover plate</p>	<p>Remove connection screws connecting the top panel with the front panel and the right side plate, and then remove the top panel.</p> 

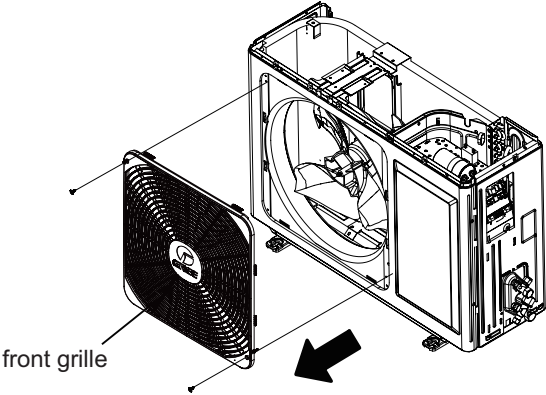
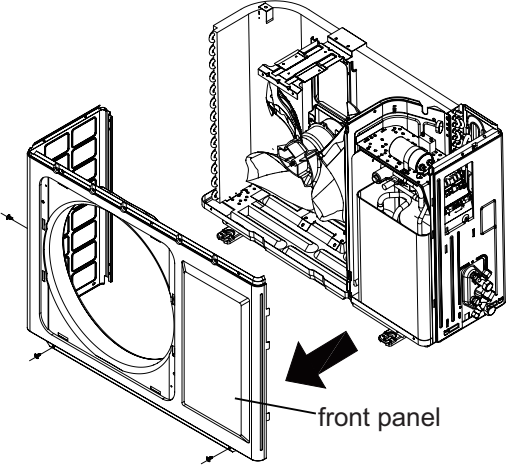
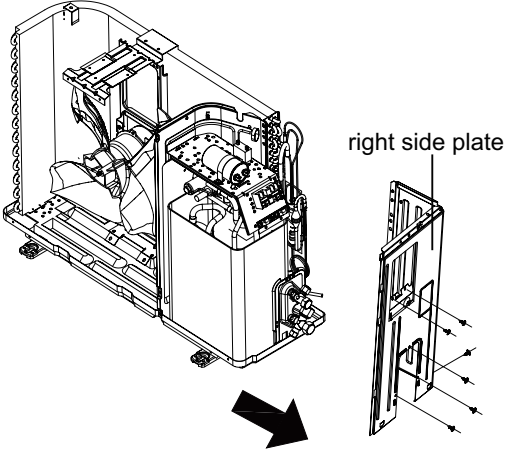
Steps	Procedure
<p>4. Remove front grille</p>	<p>Remove connection screws between the front grille and the front panel. Then remove the front grille.</p>  <p>front grille</p>
<p>5. Remove front panel</p>	<p>Remove connection screws connecting the front panel with the chassis and the motor support and then remove the front panel.</p>  <p>front panel</p>
<p>6. Remove right side plate</p>	<p>Remove connection screws connecting the right side plate with the valve support and the electric box. Then remove the right side plate.</p>  <p>right side plate</p>

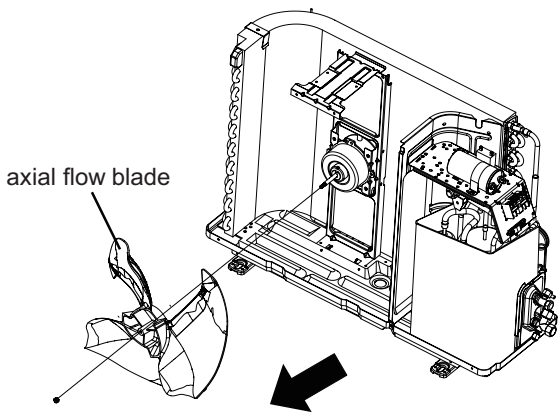
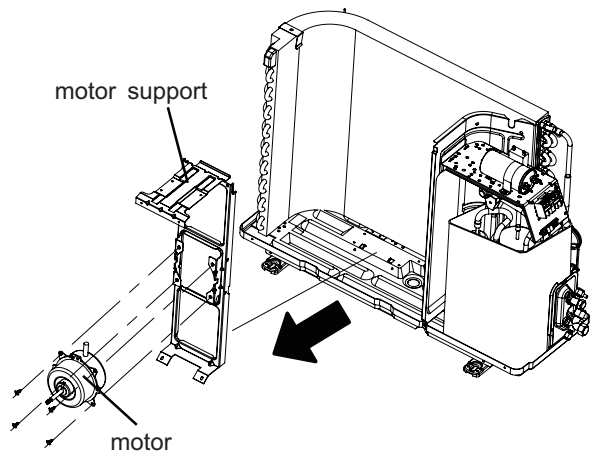
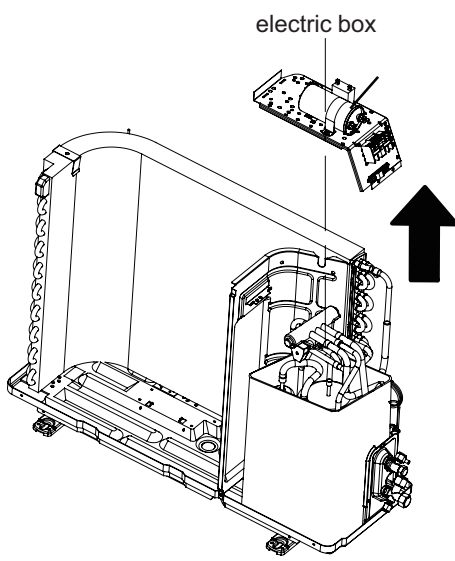
Steps	Procedure	
<p>7. Remove axial flow blade</p>	<p>Remove the nut on the blade and then remove the axial flow blade.</p>	 <p>axial flow blade</p>
<p>8. Remove motor and motor support</p>	<p>Remove the 4 tapping screws fixing the motor and disconnect the leading wire insert of the motor. Then remove the motor. Remove the 2 tapping screws fixing the motor support and lift the motor support to remove it.</p>	 <p>motor support</p> <p>motor</p>
<p>9. Remove electric box</p>	<p>Remove screws fixing the electric box subassembly; loosen the wire bundle and unplug the wiring terminals. Then lift the electric box to remove it.</p>	 <p>electric box</p>

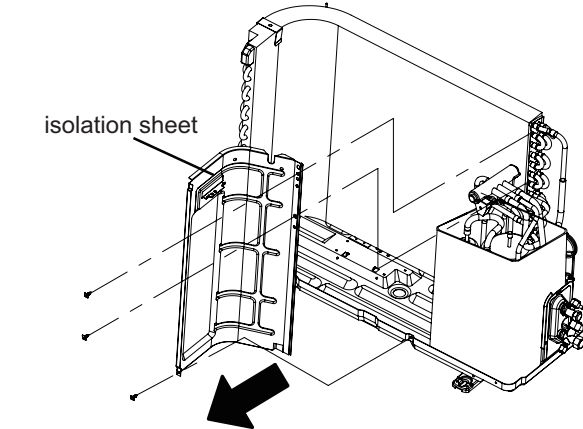
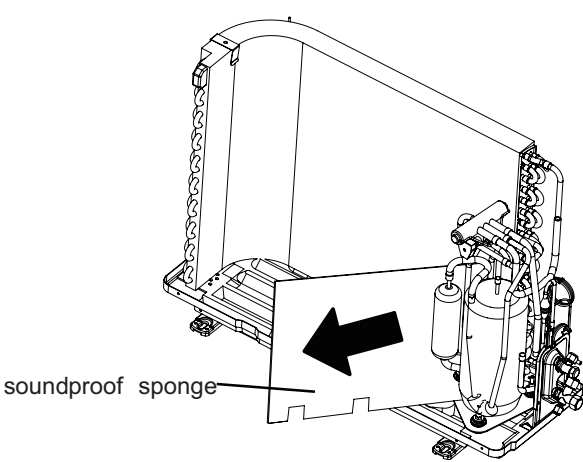
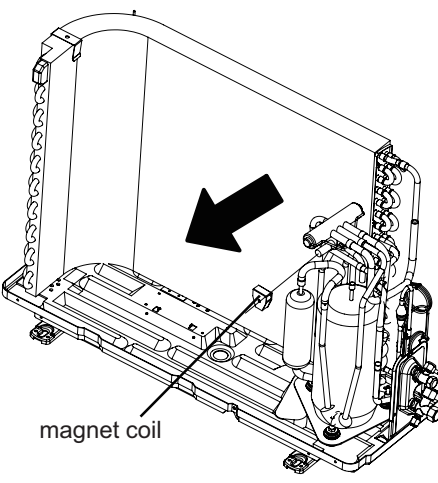
Steps	Procedure
<p>10. Remove isolation sheet</p>	<p>Remove the 3 screws fixing the isolation sheet and then remove the isolation sheet.</p> 
<p>11. Remove soundproof sponge</p>	<p>Remove the soundproof sponge wrapping the compressor.</p> 
<p>12. Remove magnet coil</p>	<p>Remove the screw fixing the magnet coil and then remove the coil.</p> 

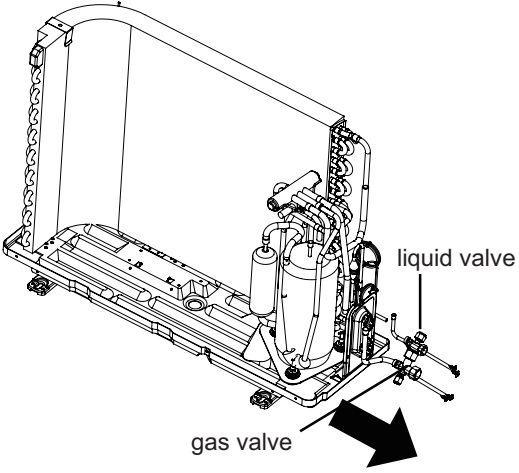
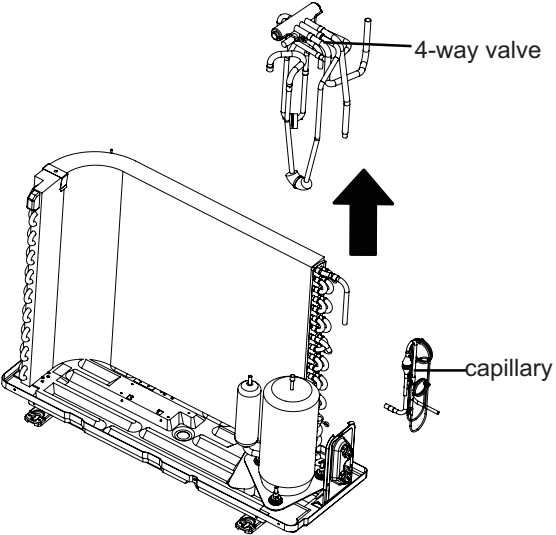
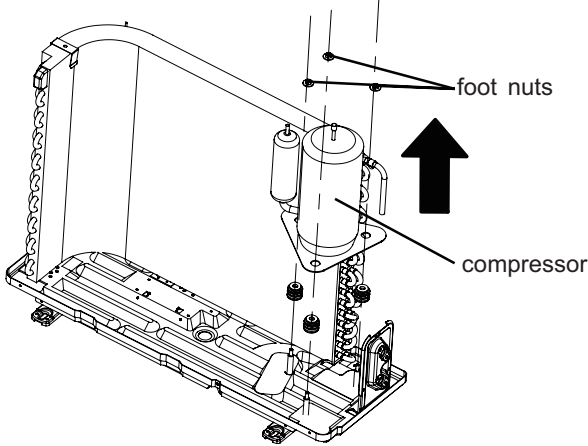
Step	Procedure	
<p>13. Remove liquid valve and gas valve</p>		
	<p>Unsolder the welding joint connecting the capillary, valves and the outlet pipe of condenser to remove the capillary. Do not block the capillary with welding slag during unsoldering.</p> <p>Remove the 2 screws fixing the gas valve and unsolder the welding joint between the gas valve and the air-return pipe to remove the gas valve. (NOTE: Discharge the refrigerant completely before unsoldering; when unsoldering, wrap the gas valve with a wet cloth completely to avoid damage to the valve caused by high temperature).</p> <p>Remove the 2 screws fixing the liquid valve and unsolder the welding joint connecting the liquid valve to the Y-type pipe to remove the liquid valve.</p>	
<p>14. Remove compressor</p>		
<p>a</p>	<p>Unsolder pipes connecting with compressor.</p>	
<p>b</p>	<p>Remove the 3 foot nuts on the compressor and then remove the compressor.</p>	

GWH12AAB-K3NNA2A/O

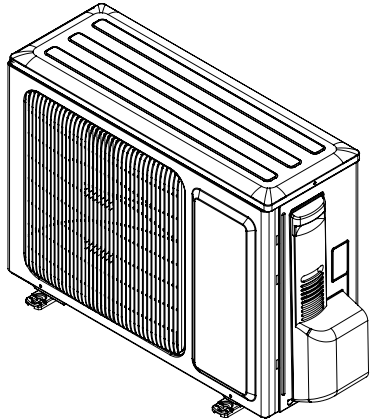
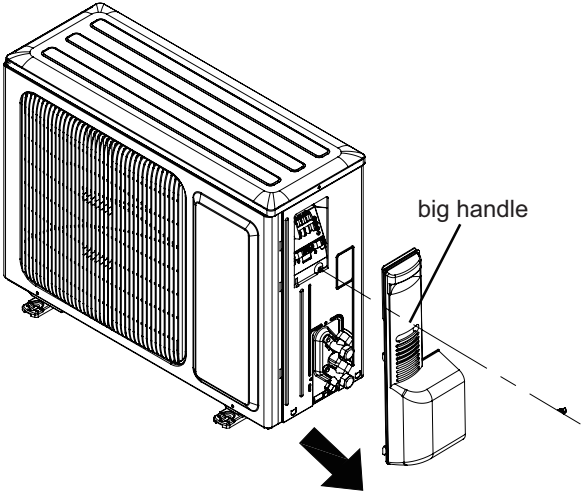
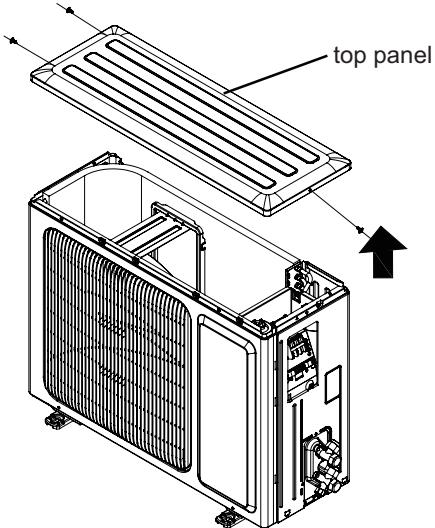
Step	Procedure
<p>1. Before disassembly</p>	
<p>2. Remove big handle</p>	<p>Remove the connection screw fixing the big handle and then remove the handle.</p> 
<p>3. Remove top panel</p>	<p>Remove connection screws connecting the top panel with the front panel and the right side plate, and then remove the top panel.</p> 

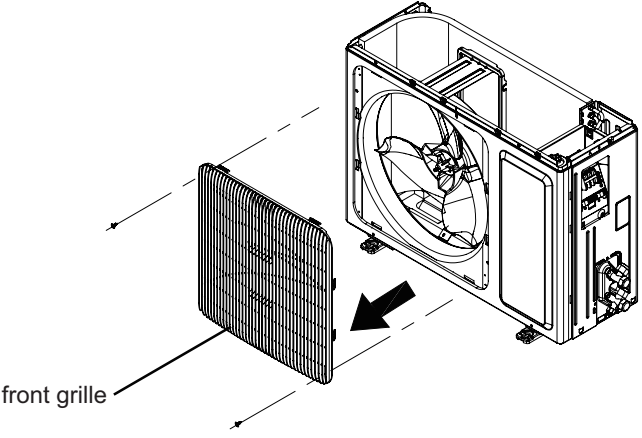
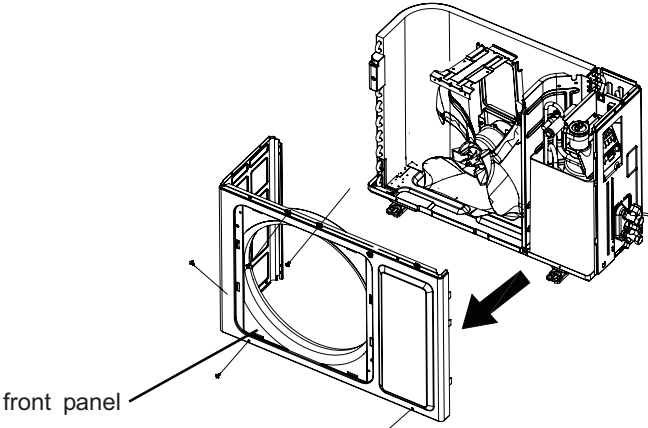
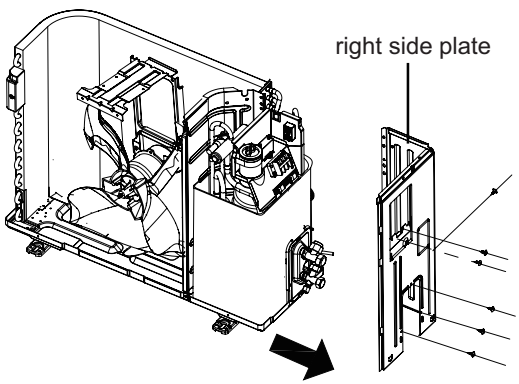
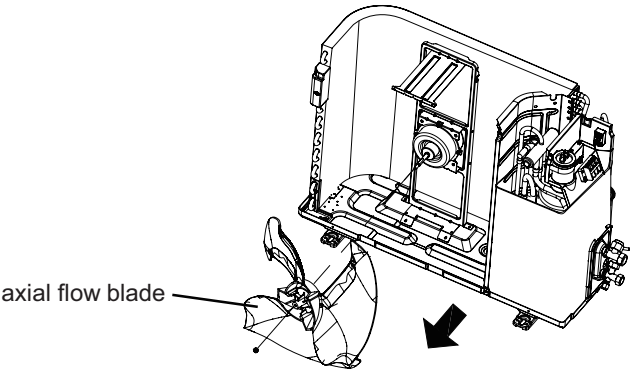
Step	Procedure	
<p>4. Remove front grille</p>	<p>Remove connection screws between the front grille and the front panel. Then remove the front grille.</p>	 <p>The diagram shows an exploded view of the front grille and the front panel. A thick black arrow points from the grille towards the panel, indicating the removal direction. A label 'front grille' with a leader line points to the grille.</p>
<p>5. Remove front panel</p>	<p>Remove connection screws connecting the front panel with the chassis and the motor support, and then remove the front panel.</p>	 <p>The diagram shows the front panel being separated from the main chassis. A thick black arrow points from the panel towards the chassis. A label 'front panel' with a leader line points to the panel.</p>
<p>6. Remove right side plate</p>	<p>Remove connection screws connecting the right side plate with the chassis, the valve support and the electric box. Then remove the right side plate.</p>	 <p>The diagram shows the right side plate being removed from the chassis. A thick black arrow points from the plate towards the chassis. A label 'right side plate' with a leader line points to the plate.</p>
<p>7. Remove axial flow blade</p>	<p>Remove the nut on the blade and then remove the axial flow blade.</p>	 <p>The diagram shows the axial flow blade being removed from the motor assembly. A thick black arrow points from the blade towards the motor. A label 'axial flow blade' with a leader line points to the blade.</p>

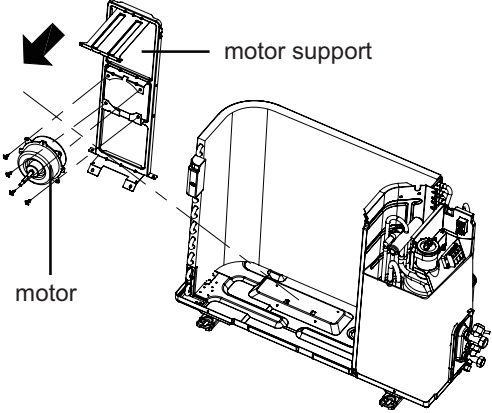
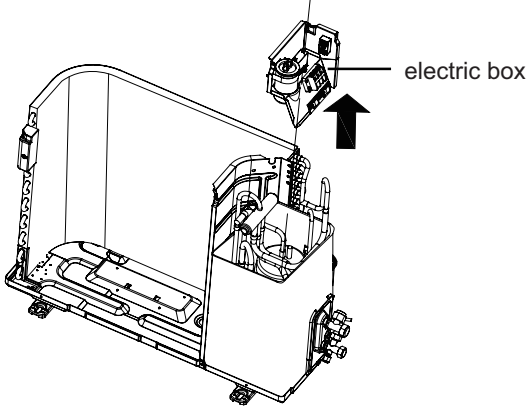
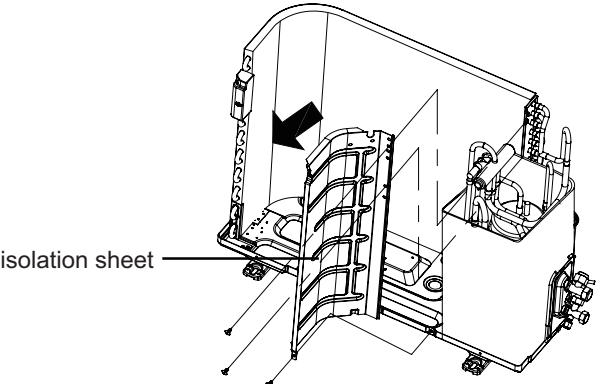
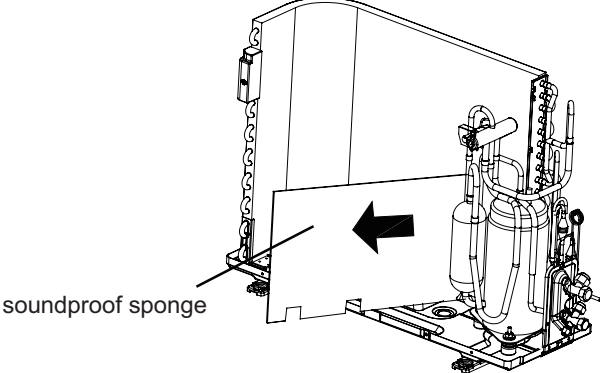
Step	Procedure	
<p>8. Remove motor and motor support</p>	<p>Remove the 4 tapping screws fixing the motor and disconnect the leading wire insert of the motor. Then remove the motor. Remove the 2 tapping screws fixing the motor support and lift the motor support to remove it.</p>	
<p>9. Remove electric box</p>	<p>Remove screws fixing the electric box subassembly; loosen the wire bundle and unplug the wiring terminals. Then lift the electric box to remove it.</p>	
<p>10. Remove isolation sheet</p>	<p>Remove the 3 screws fixing the isolation sheet and then remove the isolation sheet.</p>	
<p>11. Remove soundproof sponge</p>	<p>Remove the soundproof sponge wrapping the compressor.</p>	

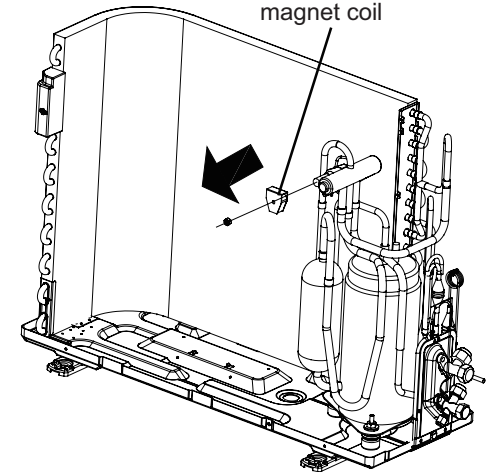
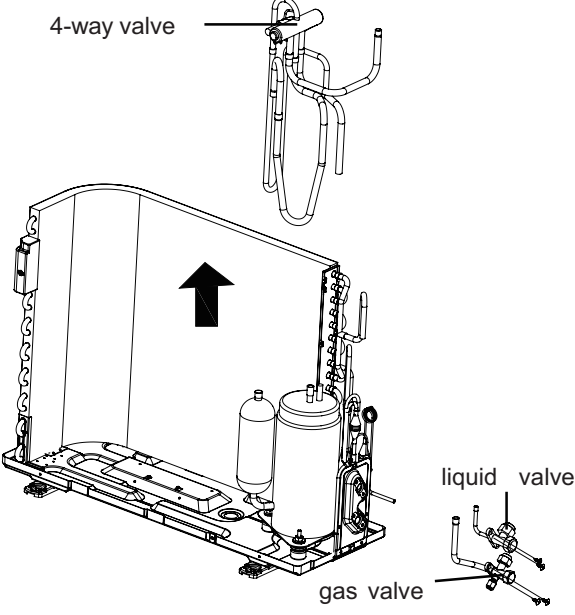
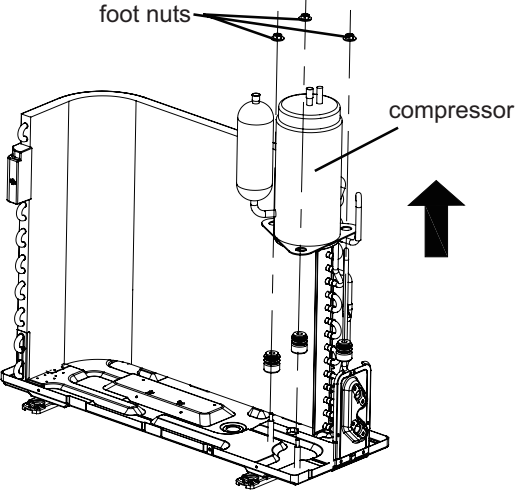
Step	Procedure	
<p>12. Remove magnet coil</p>	<p>Remove the screw fixing the magnet coil and then remove the coil.</p>	
<p>13. Remove valves and 4-way valve subassembly</p>	<p>Unsolder welding joint connecting the capillary, the valve and the outlet pipe of condenser to remove the capillary. Do not block the capillary with welding slag during unsoldering. Remove the 2 screws fixing the gas valve and unsolder the welding point between the gas valve and the air-return pipe to remove the gas valve. (NOTE: Discharge the refrigerant completely before unsoldering; when unsoldering, wrap the gas valve with a wet cloth completely to avoid damage to the valve caused by high temperature). Remove the 2 screws fixing the liquid valve and unsolder the welding joint connecting the liquid valve to the Y-type pipe to remove the liquid valve. Unsolder the welding joint connecting the 4-way valve, the compressor and the condenser to remove the 4-way valve.</p>	
<p>14. Remove compressor</p>	<p>Remove the foot nuts on the compressor and then remove the compressor.</p>	

GWH24AAD-K3NNA1A/O(CA115W14300)

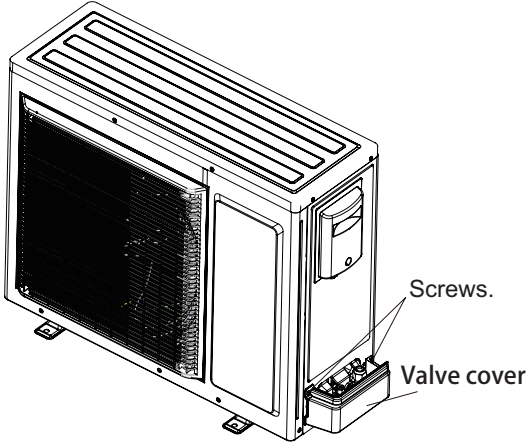
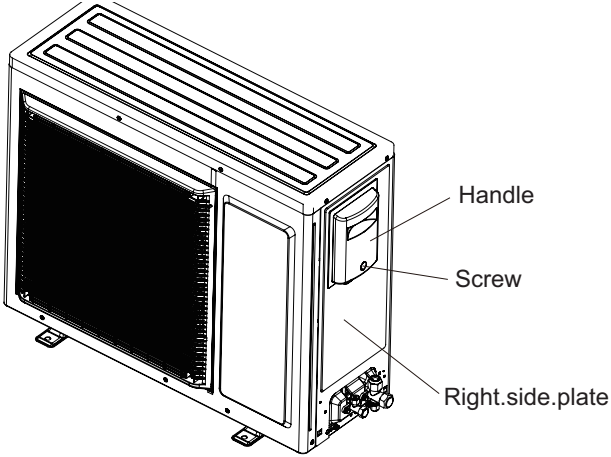
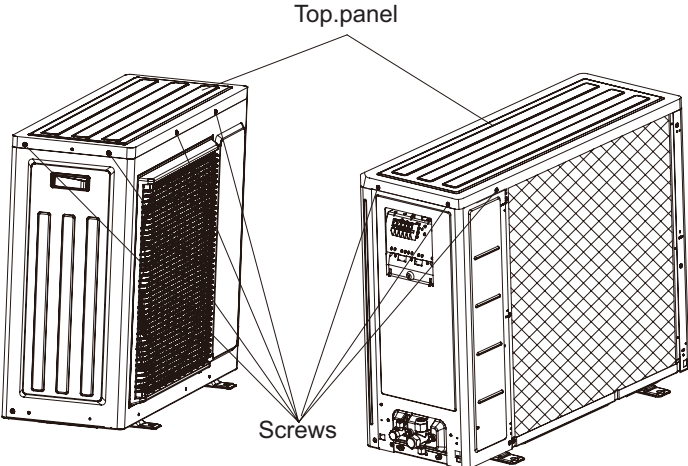
Step	Procedure	
1. Remove valve cover	Remove the 2 screws fixing valve cover and then remove the valve cover.	
2..Remove.handle	Remove the screw fixing handle; slide out the handle upwards to make the clasp of handle separate from the groove of right side plate, and then remove the handle.	
3..Remove.top.panel	Remove the screws fixing top panel and then remove the top panel.	

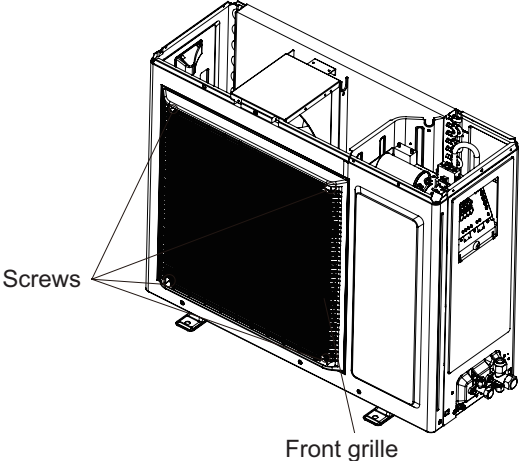
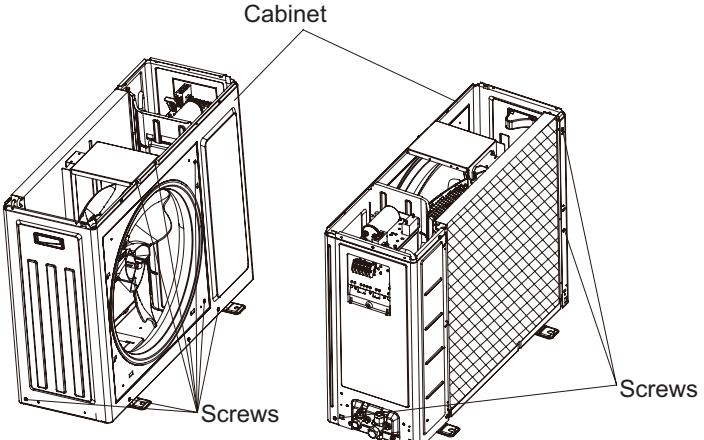
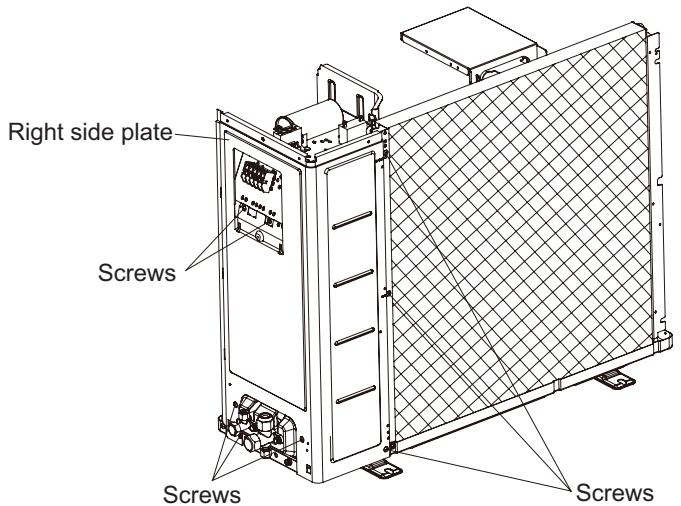
Step	Procedure	
4. Remove front grille	Remove the screws of grille and then remove the front grille.	
5. Remove cabinet	Remove the cabinet by screwing off the locking screws on cabinet.	
6. Remove right side plate	Remove the screws fixing right side plate and then remove the right side plate.	

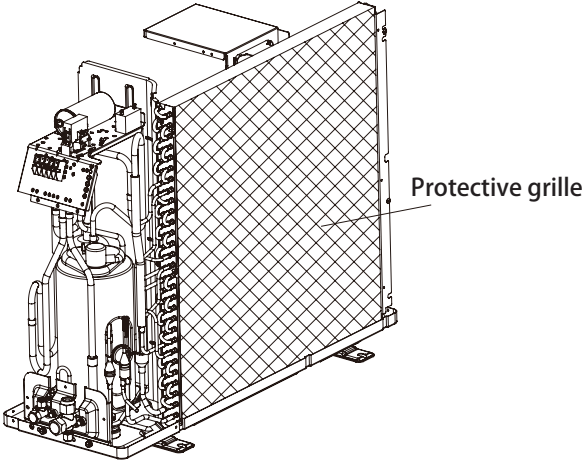
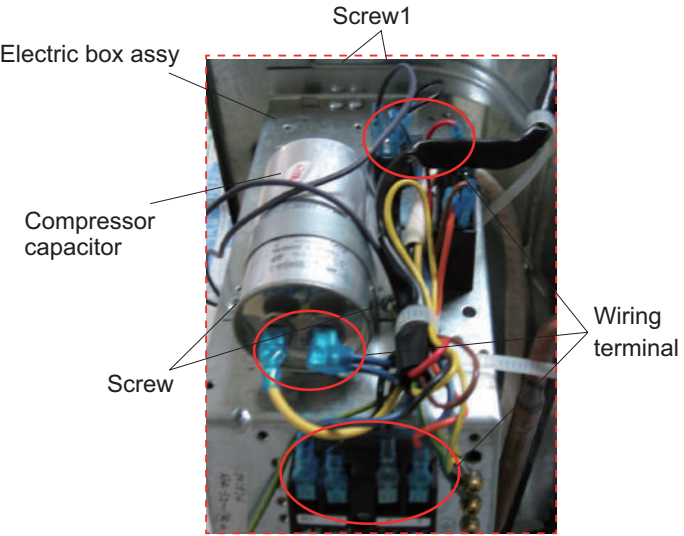
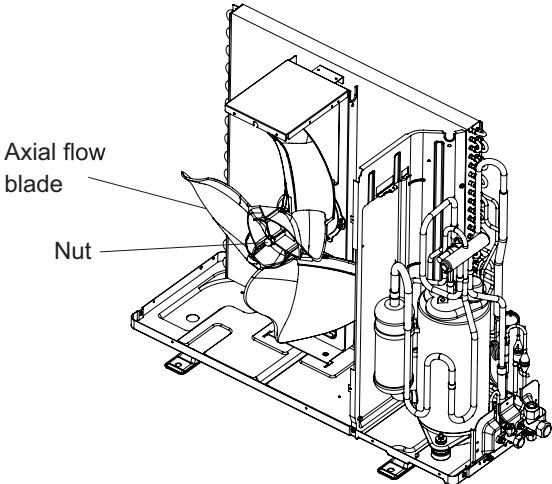
Step	Procedure	Procedure
7. Remove protective grille	Cut off the wire binder fixing the protective grille and then remove the protective grille.	 <p>A technical line drawing showing the rear view of the compressor unit. A large rectangular protective grille with a diamond mesh pattern is attached to the back of the unit. A label 'Protective grille' points to the mesh. The grille is held in place by a wire binder along its top edge.</p>
8. Remove electric box assy	Remove the wiring terminals on electric box. Screw off screw 1 fixing the electric box assy and then remove the electric box assy. Screw off the screws fixing compressor capacitor. Then remove the compressor capacitor.	 <p>A photograph showing the internal components of the compressor unit. A red dashed box highlights the electric box assembly. Labels include 'Screw1' pointing to a screw on the top of the electric box, 'Electric box assy' pointing to the box itself, 'Compressor capacitor' pointing to a cylindrical component, 'Screw' pointing to a screw on the capacitor, and 'Wiring terminal' pointing to a bundle of colored wires.</p>
9. Remove axial flow blade	Remove the nut fixing axial flow blade and then remove the axial flow blade.	 <p>A technical line drawing showing the axial flow blade assembly. The blade is a curved, fan-like component mounted on a base. A label 'Axial flow blade' points to the blade itself, and another label 'Nut' points to a nut that secures the blade to the base.</p>

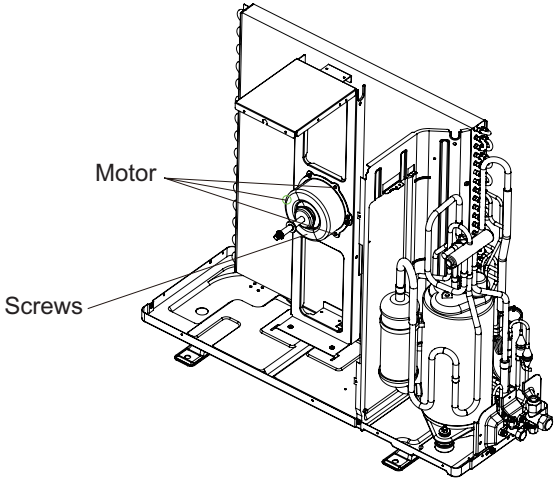
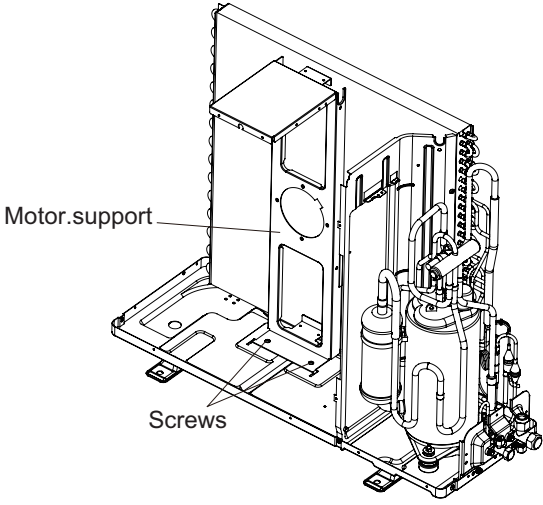
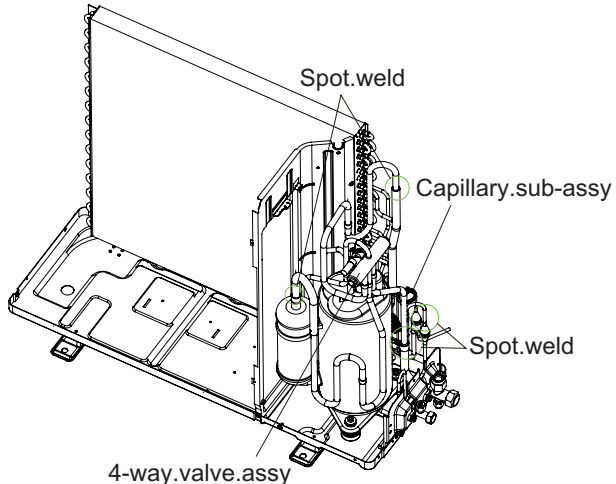
Step	Procedure	Procedure
10..Remove.motor		
	<p>Remove.the.screws.fixing.motor.and.then.remove.the.motor.</p>	
11..Remove.motor.support		
	<p>Remove.the.screws.fixing.motor.support.and.then.remove.the.motor.support.</p>	
12..Remove.4.way.valve.assy.and.capillary.sub-assy		
	<p>Unsolder.the.spot.weld.of.4-way.valve.assy.,capillary,.compressor.and.condenser,.and.then.remove.the.4-way.valve.assy.and.capillary.sub-assy.</p> <p>Note: When.unsoldering.the.spot.weld,.wrap.the.4-way.valve.with.wet.cloth.completely.to.avoid.damaging.the.valve.due.to.high.temperature.</p>	

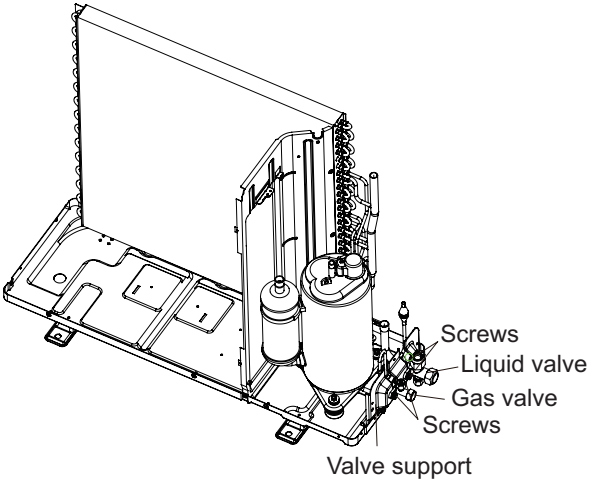
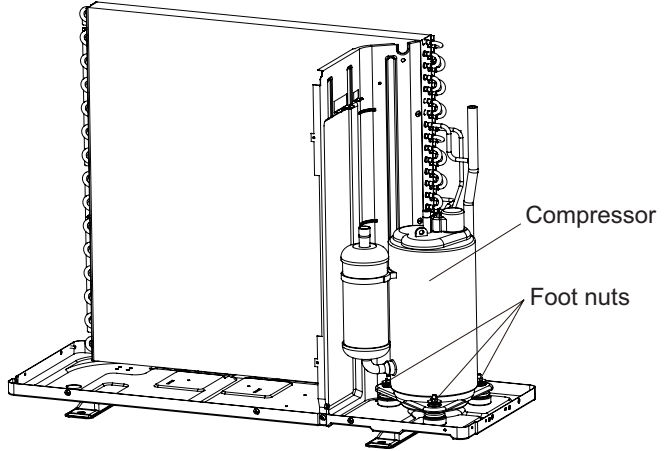
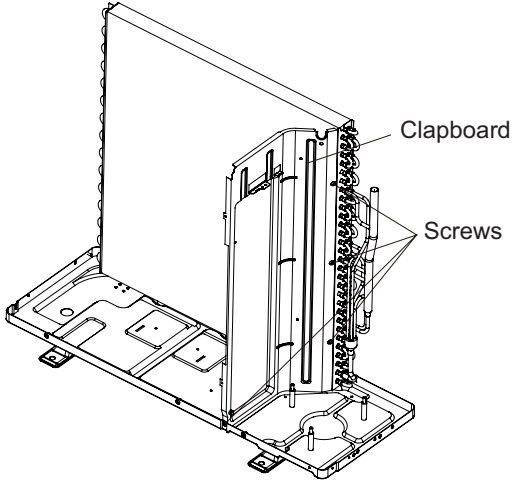
Step	Procedure	Procedure
13. Remove gas valve and liquid valve	<p>Remove two screws fixing the gas valve, then remove the gas valve.</p> <p>Remove two screws fixing the liquid valve, then remove the liquid valve.</p> <p>Screw off the screws fixing the valve support and then remove the valve support.</p>	
14. Remove compressor	<p>Remove 3 foot nuts on compressor, and then remove the compressor.</p> <p>Note: Protect the ports of discharge pipe and suction pipe to avoid foreign objects to enter it.</p>	
15. Remove clapboard	<p>Remove the screws fixing clapboard and then remove the clapboard.</p>	

GWH24AAD-K3NNA1A/O(CA115W14301)

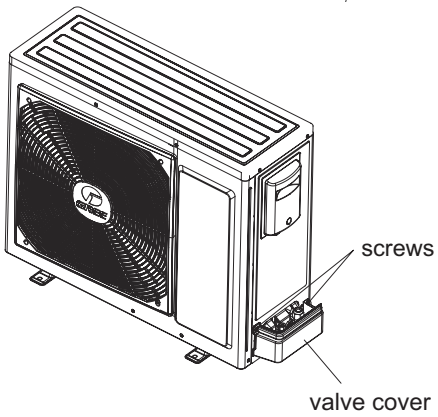
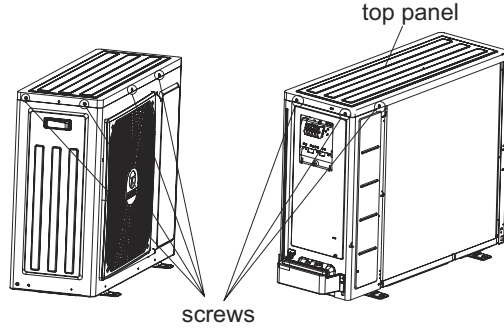
Step	Procedure
<p>1. Remove handle and valve cover</p> <p>a</p> <p>Remove the screw fixing the valve vcover then remove them.</p> <p>b</p> <p>Remove the screws fixing the handle then remove them.</p>	
<p>2. Remove top panel</p>	<p>Remove screws connecting the top panel with the front panel and the right side plate, and then remove the top panel.</p> 

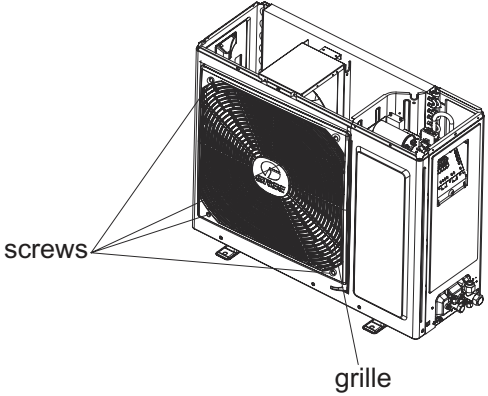
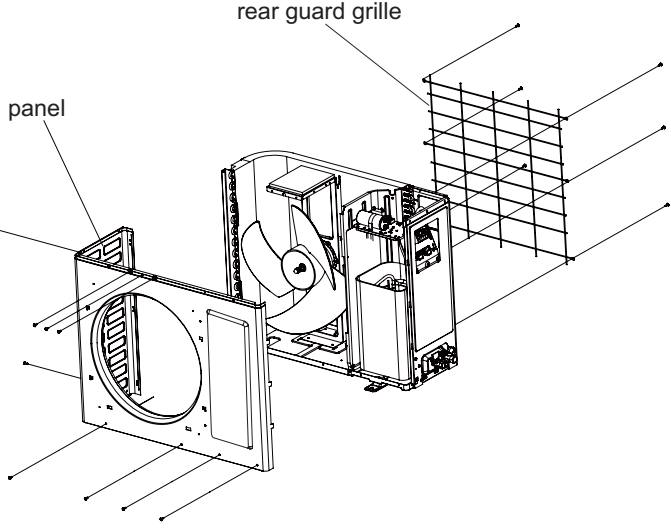
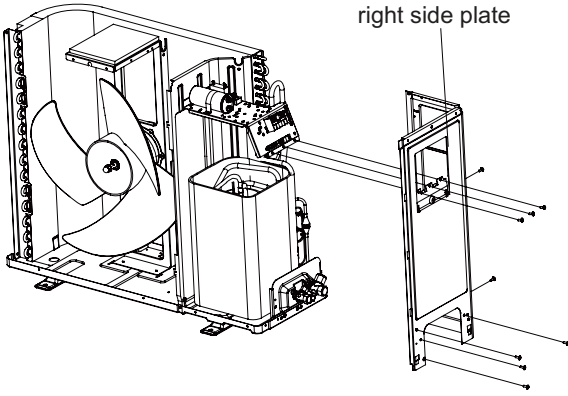
Step	Procedure	
<p data-bbox="107 257 613 288">3. Remove grille, front panel and rear guard grille</p> <p data-bbox="126 467 732 524">a Remove the screws connecting the grille and the front panel, and then remove the grille.</p> <p data-bbox="126 1105 776 1227">b Remove the screws fixing the rear guard grille and then remove the rear guard grille; remove the screws connecting the front panel with the chassis and the motor support, and then remove the front panel.</p>		 
<p data-bbox="107 1458 386 1489">4. Remove right side plate</p>	<p data-bbox="224 1690 753 1777">Remove the screws connecting the right side plate with the chassis, the valve support and the electric box, and then remove the right side plate.</p>	

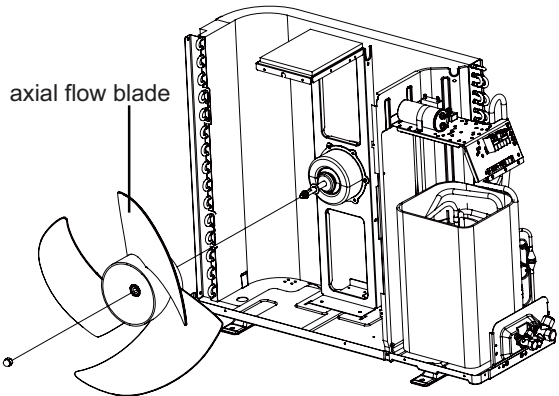
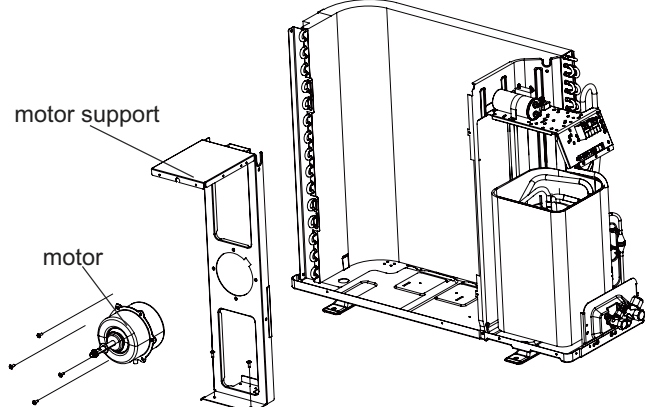
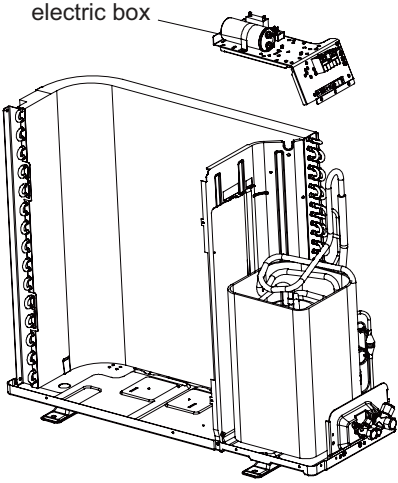
Step	Procedure	
5. Remove axial flow blade and motor		
a	Remove the nut on the blade with wrench and then remove the axial flow blade.	 <p>axial flow blade</p>
b	Remove the tapping screws fixing the motor; disconnect the leading wire insert of the motor, and then remove the motor. Remove the tapping screws fixing the motor support and then pull the motor support upwards to remove it.	 <p>motor support</p> <p>motor</p>
6. Remove electric box		
	Remove screws fixing the electric box; pull out all the wiring terminals connected to the electric box, and then pull the electric box upwards to remove it.	 <p>electric box</p>

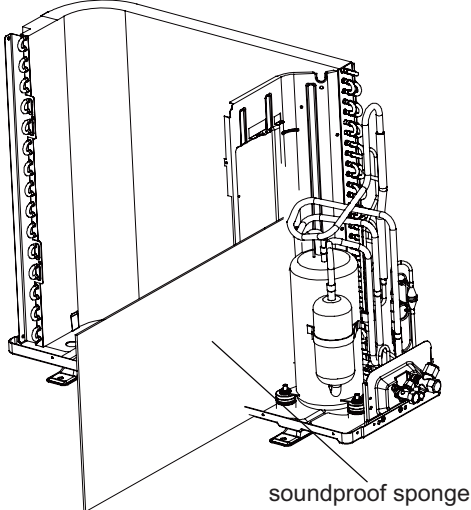
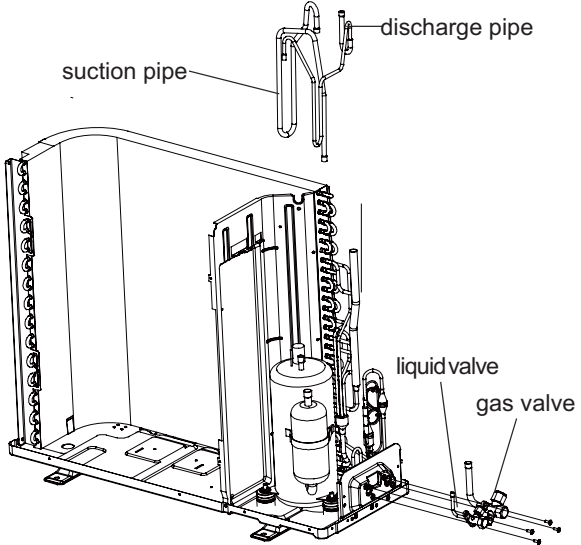
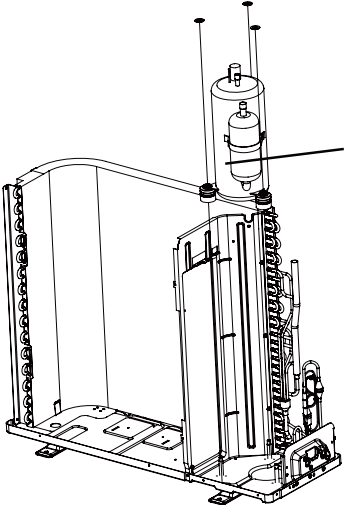
Step	Procedure
<p>7. Remove soundproof sponge</p>	<p>Remove the soundproof sponge wrapping the compressor.</p>  <p style="text-align: right;">soundproof sponge</p>
<p>8. Remove valves and pipeline</p>	<p>Remove the screws fixing the gas valve; unsolder the welding joint between the gas valve and the air-return pipe to remove the gas valve. (NOTE: Before unsoldering the welding joint, wrap the gas valve with a wet cloth completely to avoid damage to the valve caused by high temperature.) Remove the screws fixing the liquid valve; unsolder the welding joint between the liquid valve and Y-type tube to remove the liquid valve. Unsolder the pipelines connected to the compressor at first. (NOTE: Before unsoldering the pipeline, discharge the refrigerant completely)</p>  <p style="text-align: right;">discharge pipe suction pipe liquid valve gas valve</p>
<p>9. Remove compressor</p>	<p>Remove the foot nuts on the compressor and then remove the compressor.</p>  <p style="text-align: right;">compressor</p>

Step	Procedure
10. Remove isolation sheet and valve support	
a	<p>Remove screws fixing the isolation sheet and then remove the isolation sheet.</p>
b	<p>Remove screws fixing valve support and then remove the valve support; remove the screw fixing the condenser and then pull the condenser upwards to remove it.</p>

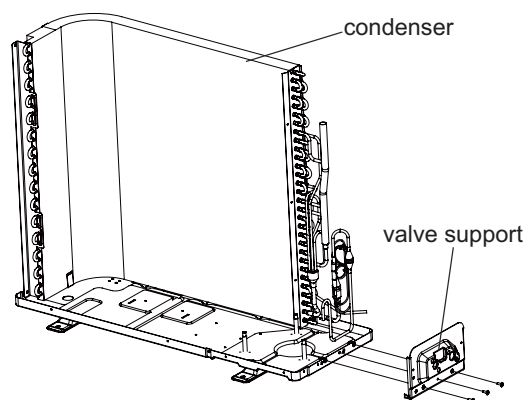
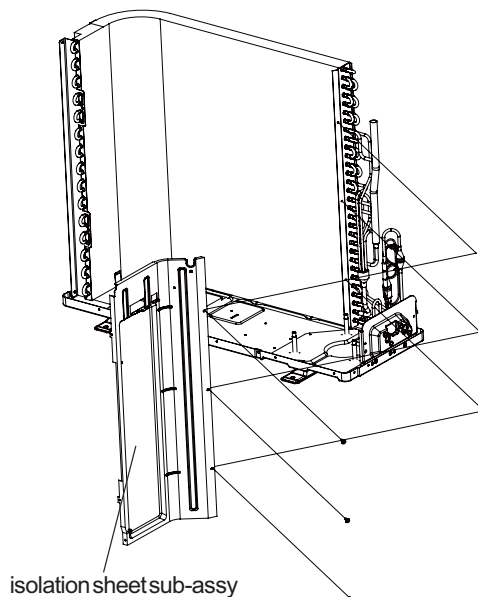

Appendix:

Appendix 1: Reference Sheet of Celsius and Fahrenheit

Conversion formula for Fahrenheit degree and Celsius degree: $T_f = T_c \times 1.8 + 32$

Set temperature

Fahrenheit display temperature (°F)	Fahrenheit (°F)	Celsius(°C)	Fahrenheit display temperature (°F)	Fahrenheit (°F)	Celsius(°C)	Fahrenheit display temperature (°F)	Fahrenheit (°F)	Celsius(°C)
61	60.8	16	69/70	69.8	21	78/79	78.8	26
62/63	62.6	17	71/72	71.6	22	80/81	80.6	27
64/65	64.4	18	73/74	73.4	23	82/83	82.4	28
66/67	66.2	19	75/76	75.2	24	84/85	84.2	29
68	68	20	77	77	25	86	86	30

Ambient temperature

Fahrenheit display temperature (°F)	Fahrenheit (°F)	Celsius(°C)	Fahrenheit display temperature (°F)	Fahrenheit (°F)	Celsius(°C)	Fahrenheit display temperature (°F)	Fahrenheit (°F)	Celsius(°C)
32/33	32	0	55/56	55.4	13	79/80	78.8	26
34/35	33.8	1	57/58	57.2	14	81	80.6	27
36	35.6	2	59/60	59	15	82/83	82.4	28
37/38	37.4	3	61/62	60.8	16	84/85	84.2	29
39/40	39.2	4	63	62.6	17	86/87	86	30
41/42	41	5	64/65	64.4	18	88/89	87.8	31
43/44	42.8	6	66/67	66.2	19	90	89.6	32
45	44.6	7	68/69	68	20	91/92	91.4	33
46/47	46.4	8	70/71	69.8	21	93/94	93.2	34
48/49	48.2	9	72	71.6	22	95/96	95	35
50/51	50	10	73/74	73.4	23	97/98	96.8	36
52/53	51.8	11	75/76	75.2	24	99	98.6	37
54	53.6	12	77/78	77	25			

Appendix 2: Configuration of Connection Pipe

1. Standard length of connection pipe

- 5m, 7.5m, 8m.

2. Min. length of connection pipe is 3m.

3. Max. length of connection pipe and max. high difference. (More details please refer to the specifications.)

4. The additional refrigerant oil and refrigerant charging required after prolonging connection pipe

- After the length of connection pipe is prolonged for 10m at the basis of standard length, you should add 5ml of refrigerant oil for each additional 5m of connection pipe.
- The calculation method of additional refrigerant charging amount (on the basis of liquid pipe):
- Basing on the length of standard pipe, add refrigerant according to the requirement as shown in the table. The additional refrigerant charging amount per meter is different according to the diameter of liquid pipe. See the following sheet.
- Additional refrigerant charging amount = prolonged length of liquid pipe X additional refrigerant charging amount per meter

Additional refrigerant charging amount for R22, R407C, R410A and R134a			
Diameter of connection pipe		Outdoor unit throttle	
Liquid pipe(mm)	Gas pipe(mm)	Cooling only(g/m)	Cooling and heating(g/m)
Φ6	Φ9.5 or Φ12	15	20
Φ6 or Φ9.5	Φ16 or Φ19	15	50
Φ12	Φ19 or Φ22.2	30	120
Φ16	Φ25.4 or Φ31.8	60	120
Φ19	/	250	250
Φ22.2	/	350	350

Appendix 2: Pipe Expanding Method

⚠ Note:

Improper pipe expanding is the main cause of refrigerant leakage. Please expand the pipe according to the following steps:

A: Cut the pip

- Confirm the pipe length according to the distance of indoor unit and outdoor unit.
- Cut the required pipe with pipe cutter.

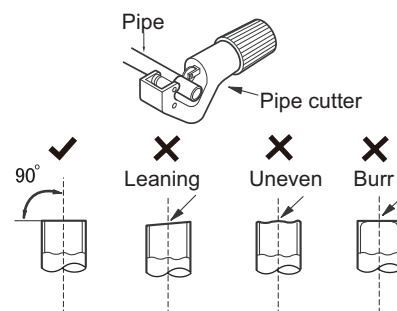

B: Remove the burrs

- Remove the burrs with shaper and prevent the burrs from getting into the pipe.

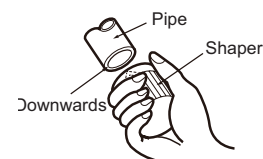

C: Put on suitable insulating pipe

D: Put on the union nut

- Remove the union nut on the indoor connection pipe and outdoor valve; install the union nut on the pipe.

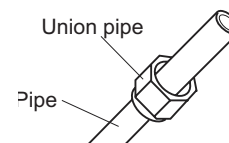

E: Expand the port

- Expand the port with expander.

⚠ Note:

- "A" is different according to the diameter, please refer to the sheet below:

Outer diameter(mm)	A(mm)	
	Max	Min
Φ6 - 6.35 (1/4")	1.3	0.7
Φ9.52 (3/8")	1.6	1.0
Φ12 - 12.70 (1/2")	1.8	1.0
Φ16 - 15.88 (5/8")	2.4	2.2

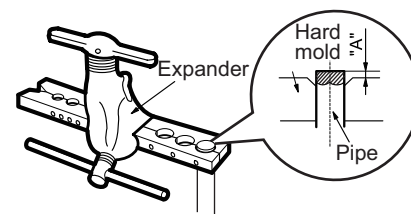

F: Inspection

- Check the quality of expanding port. If there is any blemish, expand the port again according to the steps above.

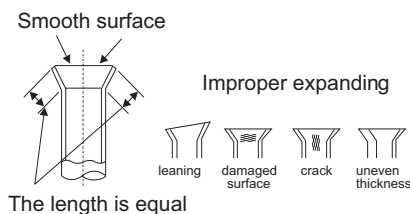

<https://climagroup.com.ua/brands/gree>

Appendix 4: List of Resistance for Temperature Sensor

Resistance Table of Ambient Temperature Sensor for Indoor and Outdoor (15K)

Temp(°C)	Resistance(kΩ)	Temp(°C)	Resistance(kΩ)	Temp(°C)	Resistance(kΩ)	Temp(°C)	Resistance(kΩ)
-19	138.1	20	18.75	59	3.848	98	1.071
-18	128.6	21	17.93	60	3.711	99	1.039
-17	121.6	22	17.14	61	3.579	100	1.009
-16	115	23	16.39	62	3.454	101	0.98
-15	108.7	24	15.68	63	3.333	102	0.952
-14	102.9	25	15	64	3.217	103	0.925
-13	97.4	26	14.36	65	3.105	104	0.898
-12	92.22	27	13.74	66	2.998	105	0.873
-11	87.35	28	13.16	67	2.896	106	0.848
-10	82.75	29	12.6	68	2.797	107	0.825
-9	78.43	30	12.07	69	2.702	108	0.802
-8	74.35	31	11.57	70	2.611	109	0.779
-7	70.5	32	11.09	71	2.523	110	0.758
-6	66.88	33	10.63	72	2.439	111	0.737
-5	63.46	34	10.2	73	2.358	112	0.717
-4	60.23	35	9.779	74	2.28	113	0.697
-3	57.18	36	9.382	75	2.206	114	0.678
-2	54.31	37	9.003	76	2.133	115	0.66
-1	51.59	38	8.642	77	2.064	116	0.642
0	49.02	39	8.297	78	1.997	117	0.625
1	46.6	40	7.967	79	1.933	118	0.608
2	44.31	41	7.653	80	1.871	119	0.592
3	42.14	42	7.352	81	1.811	120	0.577
4	40.09	43	7.065	82	1.754	121	0.561
5	38.15	44	6.791	83	1.699	122	0.547
6	36.32	45	6.529	84	1.645	123	0.532
7	34.58	46	6.278	85	1.594	124	0.519
8	32.94	47	6.038	86	1.544	125	0.505
9	31.38	48	5.809	87	1.497	126	0.492
10	29.9	49	5.589	88	1.451	127	0.48
11	28.51	50	5.379	89	1.408	128	0.467
12	27.18	51	5.197	90	1.363	129	0.456
13	25.92	52	4.986	91	1.322	130	0.444
14	24.73	53	4.802	92	1.282	131	0.433
15	23.6	54	4.625	93	1.244	132	0.422
16	22.53	55	4.456	94	1.207	133	0.412
17	21.51	56	4.294	95	1.171	134	0.401
18	20.54	57	4.139	96	1.136	135	0.391
19	19.63	58	3.99	97	1.103	136	0.382

Resistance Table of Tube Temperature Sensors for Outdoor and Indoor (20K)

Temp(°C)	Resistance(kΩ)	Temp(°C)	Resistance(kΩ)	Temp(°C)	Resistance(kΩ)	Temp(°C)	Resistance(kΩ)
-19	181.4	20	25.01	59	5.13	98	1.427
-18	171.4	21	23.9	60	4.948	99	1.386
-17	162.1	22	22.85	61	4.773	100	1.346
-16	153.3	23	21.85	62	4.605	101	1.307
-15	145	24	20.9	63	4.443	102	1.269
-14	137.2	25	20	64	4.289	103	1.233
-13	129.9	26	19.14	65	4.14	104	1.198
-12	123	27	18.13	66	3.998	105	1.164
-11	116.5	28	17.55	67	3.861	106	1.131
-10	110.3	29	16.8	68	3.729	107	1.099
-9	104.6	30	16.1	69	3.603	108	1.069
-8	99.13	31	15.43	70	3.481	109	1.039
-7	94	32	14.79	71	3.364	110	1.01
-6	89.17	33	14.18	72	3.252	111	0.983
-5	84.61	34	13.59	73	3.144	112	0.956
-4	80.31	35	13.04	74	3.04	113	0.93
-3	76.24	36	12.51	75	2.94	114	0.904
-2	72.41	37	12	76	2.844	115	0.88
-1	68.79	38	11.52	77	2.752	116	0.856
0	65.37	39	11.06	78	2.663	117	0.833
1	62.13	40	10.62	79	2.577	118	0.811
2	59.08	41	10.2	80	2.495	119	0.77
3	56.19	42	9.803	81	2.415	120	0.769
4	53.46	43	9.42	82	2.339	121	0.746
5	50.87	44	9.054	83	2.265	122	0.729
6	48.42	45	8.705	84	2.194	123	0.71
7	46.11	46	8.37	85	2.125	124	0.692
8	43.92	47	8.051	86	2.059	125	0.674
9	41.84	48	7.745	87	1.996	126	0.658
10	39.87	49	7.453	88	1.934	127	0.64
11	38.01	50	7.173	89	1.875	128	0.623
12	36.24	51	6.905	90	1.818	129	0.607
13	34.57	52	6.648	91	1.736	130	0.592
14	32.98	53	6.403	92	1.71	131	0.577
15	31.47	54	6.167	93	1.658	132	0.563
16	30.04	55	5.942	94	1.609	133	0.549
17	28.68	56	5.726	95	1.561	134	0.535
18	27.39	57	5.519	96	1.515	135	0.521
19	26.17	58	5.32	97	1.47	136	0.509

Resistance Table of Discharge Temperature Sensor for Outdoor (50K)

Temp(°C)	Resistance(kΩ)	Temp(°C)	Resistance(kΩ)	Temp(°C)	Resistance(kΩ)	Temp(°C)	Resistance(kΩ)
-29	853.5	10	98	49	18.34	88	4.75
-28	799.8	11	93.42	50	17.65	89	4.61
-27	750	12	89.07	51	16.99	90	4.47
-26	703.8	13	84.95	52	16.36	91	4.33
-25	660.8	14	81.05	53	15.75	92	4.20
-24	620.8	15	77.35	54	15.17	93	4.08
-23	580.6	16	73.83	55	14.62	94	3.96
-22	548.9	17	70.5	56	14.09	95	3.84
-21	516.6	18	67.34	57	13.58	96	3.73
-20	486.5	19	64.33	58	13.09	97	3.62
-19	458.3	20	61.48	59	12.62	98	3.51
-18	432	21	58.77	60	12.17	99	3.41
-17	407.4	22	56.19	61	11.74	100	3.32
-16	384.5	23	53.74	62	11.32	101	3.22
-15	362.9	24	51.41	63	10.93	102	3.13
-14	342.8	25	49.19	64	10.54	103	3.04
-13	323.9	26	47.08	65	10.18	104	2.96
-12	306.2	27	45.07	66	9.83	105	2.87
-11	289.6	28	43.16	67	9.49	106	2.79
-10	274	29	41.34	68	9.17	107	2.72
-9	259.3	30	39.61	69	8.85	108	2.64
-8	245.6	31	37.96	70	8.56	109	2.57
-7	232.6	32	36.38	71	8.27	110	2.50
-6	220.5	33	34.88	72	7.99	111	2.43
-5	209	34	33.45	73	7.73	112	2.37
-4	198.3	35	32.09	74	7.47	113	2.30
-3	199.1	36	30.79	75	7.22	114	2.24
-2	178.5	37	29.54	76	7.00	115	2.18
-1	169.5	38	28.36	77	6.76	116	2.12
0	161	39	27.23	78	6.54	117	2.07
1	153	40	26.15	79	6.33	118	2.02
2	145.4	41	25.11	80	6.13	119	1.96
3	138.3	42	24.13	81	5.93	120	1.91
4	131.5	43	23.19	82	5.75	121	1.86
5	125.1	44	22.29	83	5.57	122	1.82
6	119.1	45	21.43	84	5.39	123	1.77
7	113.4	46	20.6	85	5.22	124	1.73
8	108	47	19.81	86	5.06	125	1.68
9	102.8	48	19.06	87	4.90	126	1.64



JF00303671



GREE ELECTRIC APPLIANCES, INC. OF ZHUHAI

Add: West Jinji Rd, Qianshan, Zhuhai, Guangdong, China, 519070
Tel: (+86-756) 8522218
Fax: (+86-756) 8669426

HONG KONG GREE ELECTRIC APPLIANCES SALES LIMITED

Add: Unit 2612, 26/F., Miramar Tower 132 Nathan Road, TST, Kowloon, HK
Tel: (852) 31658898 Fax: (852) 31651029

For product improvement, specifications and appearance in this manual are subject to change without prior notice.